

Dell Networking
N2128PX-ON/N3132PX-ON
Switches

Getting Started Guide

Guide de mise en route
Guia de Noções Básicas
Guía de introducción

Regulatory Model: N2128PX-ON/
N3132PX-ON
Regulatory Type: E05W003/E06W003



Dell Networking
N2128PX-ON/N3132PX-ON
Switches
Getting Started Guide

**Regulatory Models: N2128PX-ON/
N3132PX-ON**



Notes, Cautions, and Warnings



NOTE: A NOTE indicates important information that helps you make better use of your switch.



CAUTION: A CAUTION indicates either potential damage to hardware or loss of data and tells you how to avoid the problem.



WARNING: A WARNING indicates a potential for property damage, personal injury, or death.

Copyright © 2016 Dell Inc. All rights reserved. This product is protected by U.S. and international copyright and intellectual property laws.

Dell™ and the Dell logo are trademarks of Dell Inc. in the United States and/or other jurisdictions. All other marks and names mentioned herein may be trademarks of their respective companies.

Regulatory Models N2128PX-0N/N3132PX-0N

April 2016 P/N 1VT9M Rev. A00

Contents

1	Introduction	7
	N2128PX-ON Hardware Overview.	7
	Power Consumption for N2128PX-ON PoE Switches	7
	N2128PX-ON Model Summary.	8
2	N2128PX-ON Installation	9
	Rack Mounting an N2128PX-ON Switch	9
	Installing in a Rack	9
	Installing as a Free-standing Switch	10
	Stacking Multiple N2128PX-ON Switches	10
3	Starting and Configuring the N2128PX-ON Switch	11
	Connecting an N2128PX-ON Switch to a Terminal	12
	Connecting an N2128PX-ON Switch to a Power Source	13
	AC and DC Power Connection	13
	Booting the N2128PX-ON Switch	14

	Performing the N2128PX-ON Initial Configuration	15
	Enabling Remote Management	15
	Initial Configuration Procedure	16
	Example Session	17
	Dell Easy Setup Wizard Console Example	18
	Next Steps	22
4	N3132PX-ON Hardware Overview	24
	Power Consumption for N3132PX-ON PoE Switches	24
	Ventilation System	26
	N3132PX-ON Model Summary	27
5	N3132PX-ON Installation	28
	Rack Mounting a N3132PX-ON Switch	28
	Rack Mounting Safety Considerations	28
	Installing the Dell ReadyRail System	29
	Installing as a Free-standing Switch	33
	Stacking Multiple N3132PX-ON Switches	33
6	Starting and Configuring the N3132PX-ON Switch	34
	Connecting an N3132PX-ON Switch to a Terminal	35
	Connecting an N3132PX-ON Switch to a Power Source	36
	AC and DC Power Connection	37
	Booting the N3132PX-ON Switch	37

Performing the N3132PX-ON Initial Configuration . . .	38
Enabling Remote Management.	38
Initial Configuration Procedure.	39
Example Session	40
Dell Easy Setup Wizard Console Example	41
Next Steps	45
7 NOM Information (Mexico Only)	47

Introduction

This document provides basic information about the Dell® Networking N2128PX-ON/N3132PX-ON switches, including how to install a switch and perform the initial configuration. For information about how to configure and monitor switch features, refer to the *User Configuration Guide*, which is available on the Dell Support website at dell.com/support, for the latest updates on documentation and firmware.



NOTE: Switch administrators are strongly advised to maintain Dell Networking switches on the latest version of the Dell Networking Operating System (DNOS). Dell Networking continually improves the features and functions of DNOS based on feedback from you, the customer. For critical infrastructure, pre-staging of the new release into a non-critical portion of the network is recommended to verify network configuration and operation with the new DNOS version.

N2128PX-ON Hardware Overview

This section contains information about device characteristics and modular hardware configurations for the Dell Networking N2128PX-ON switch.

Power Consumption for N2128PX-ON PoE Switches

Table 1-1 describes the power consumption for N2128PX-ON PoE switches. The system power consumption is 90 watt (W). The PoE power budget is 800W for the main power supply (PSU).

Table 1-1. Power Consumption for N2128PX-ON PoE Switches

Model	Input Voltage	Power Supply Configuration	Maximum Steady Current Consumption (A)	Maximum Steady Power (W)
N2128PX-ON	100V/60Hz	Main PSU	9.73A	965.5W
	110V/60Hz	Main PSU	8.75A	960.4W
	120V/60Hz	Main PSU	8.03A	958.3W
	220V/50Hz	Main PSU	4.33A	931W
	240V/50Hz	Main PSU	3.97A	928.7W

Table 1-2 shows power consumption data for the PoE-enabled N2128PX-ON switches operating from the Modular Power Supply (MPS) only. The PoE power budget is 800W for MPS.

Table 1-2. Power Consumption Data for N2128PX-ON Switches PoE (+ MPS)

Model	Input Voltage	Power Supply Configuration	Maximum Steady Current Consumption (A)	Maximum Steady Power (W)
N2128PX-ON	100V/60Hz	MPS	9.92A	986.5W
	110V/60Hz	MPS	8.93A	975.7W
	120V/60Hz	MPS	8.01A	955.4W
	220V/50Hz	MPS	4.44A	945.4W
	240V/50Hz	MPS	4.08A	951.4W

Table 1-3 shows power consumption data for the PoE-enabled N2128PX-ON switches. The PoE power budget is 1600W for the main power supply + Modular Power Supply (MPS).

Table 1-3. Power Consumption for N2128PX-ON PoE Switches

Model	Input Voltage	Power Supply Configuration	Maximum Steady Current Consumption (A)	Maximum Steady Power (W)
N2128PX-ON	100V/60Hz	Main PSU + MPS	11.83A	1175W
	110V/60Hz	Main PSU + MPS	10.71A	1169W
	120V/60Hz	Main PSU + MPS	9.84A	1168.9W
	220V/50Hz	Main PSU + MPS	5.4A	1138.4W
	240V/50Hz	Main PSU + MPS	5.93A	1141W

N2128PX-ON Model Summary

Table 1-4. N2128PX-ON Switch Regulatory Numbers

Marketing Model Name (MMN)	Description	Power Supply Unit (PSU)	Regulatory Model Number (RMN)	Regulatory Type Number (RTN)
N2128PX-ON	24x1G/4x2.5G/2x10G SFP+/2xStacking/24x PoE+/4xPoE 60W Ports	1000W	E05W	E05W003

N2128PX-ON Installation

Rack Mounting an N2128PX-ON Switch

⚠ WARNING: Read the safety information in the *Safety and Regulatory Information* as well as the safety information for other switches that connect to or support the switch.

The AC power connector is on the rear panel of the switch.

Installing in a Rack

⚠ WARNING: Do not use rack mounting kits to suspend the switch from under a table or desk, or attach it to a wall.

⚠ CAUTION: Disconnect all cables from the switch before continuing. Remove all self-adhesive pads from the underside of the switch, if they have been attached.

⚠ CAUTION: When mounting multiple switches into a rack, mount the switches from the bottom up.

- 1 Place the supplied rack-mounting bracket on one side of the switch, ensuring that the mounting holes on the switch line up to the mounting holes in the rack-mounting bracket. Figure 1-1 illustrates where to mount the brackets.

Figure 1-1. Attaching the Brackets



- 2 Insert the supplied bolts into the rack-mounting holes and tighten with a screwdriver.

- 3 Repeat the process for the rack-mounting bracket on the other side of the switch.
- 4 Insert the switch into the 48.26 cm (19 inch) rack, ensuring that the rack-mounting holes on the switch line up to the mounting holes in the rack.
- 5 Secure the switch to the rack with either the rack bolts or cage nuts and cage-nut bolts with washers (depending on the kind of rack you have). Fasten the bolts on bottom before fastening the bolts on top.



CAUTION: Make sure that the supplied rack bolts fit the pre-threaded holes in the rack.



NOTE: Make sure that the ventilation holes are not obstructed.

Installing as a Free-standing Switch



NOTE: Dell strongly recommends mounting the switch in a rack.

Install the switch on a flat surface if you are not installing it in a rack. The surface must be able to support the weight of the switch and the switch cables. The switch is supplied with four self-adhesive rubber pads.

- 1 Attach the self-adhesive rubber pads on each location marked on the bottom of the switch.
- 2 Set the switch on a flat surface, and make sure that it has proper ventilation by leaving 5 cm (2 inches) on each side and 13 cm (5 inches) at the back.

Stacking Multiple N2128PX-ON Switches

You can stack N2128PX-ON switches up to 12 switches high using the mini-SAS ports located on the rear of the switch. When multiple switches are connected together through the stack ports, they operate as a single unit with up to 336 front panel ports. The stack operates and is managed as a single entity. Refer to the *User Configuration Guide* and the *CLI Reference Guide* for more information.

Starting and Configuring the N2128PX-ON Switch

The following flow chart provides an overview of the steps you use to perform the initial configuration after the switch is unpacked and mounted.

Figure 1-2. Installation and Configuration Flow Chart

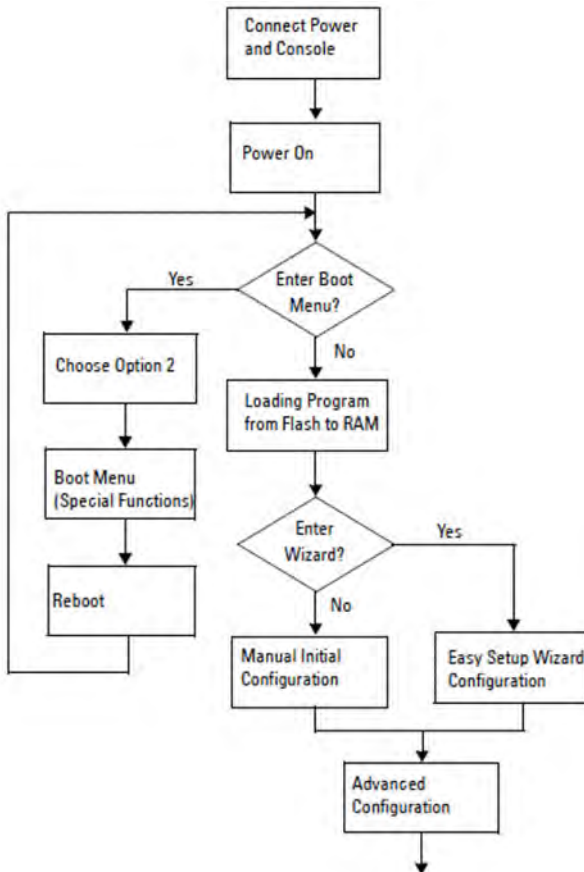

Connecting an N2128PX-ON Switch to a Terminal

After completing all external connections, configure the switch by connecting it to a terminal.



NOTE: Read the Release Notes for this product before proceeding. You can download the Release Notes from the Dell Support website at dell.com/support.



NOTE: Dell recommends that you obtain the most recent version of the user documentation from the Dell Support website at dell.com/support.

To monitor and configure the switch via serial console, use the console port on the front panel of the switch to connect it to a VT100 terminal or to a computer running VT100 terminal emulation software. The console port is implemented as a data terminal equipment (DTE) connector.

The following equipment is required to use the console port:

- VT100-compatible terminal or a computer with a serial port running VT100 terminal emulation software, such as HyperTerminal®.
- A serial cable (provided) with an RJ-45 connector for the console port and DB-9 connector for the terminal.

Perform the following tasks to connect a terminal to the switch console port:

- 1** Connect the DB-9 connector on the serial cable to the terminal or computer running VT100 terminal emulation software.
- 2** Configure the terminal emulation software as follows:
 - a** Select the appropriate serial port (for example, COM 1) to connect to the console.
 - b** Set the data rate to 115,200 baud.
 - c** Set the data format to 8 data bits, 1 stop bit, and no parity.
 - d** Set the flow control to none.
 - e** Set the terminal emulation mode to **VT100**.
 - f** Select Terminal keys for Function, Arrow, and Ctrl keys. Make sure that the setting is for Terminal keys (not Microsoft Windows keys).
- 3** Connect the RJ-45 connector on the cable directly to the switch console port. The Dell Networking console port is located on the right side of the front panel and is labeled with a |O|O| symbol.



NOTE: Serial console access to the stack manager is available from any serial port via the local CLI. Only one serial console session at a time is supported.

Connecting an N2128PX-ON Switch to a Power Source



CAUTION: Read the safety information in the *Safety and Regulatory Information* manual as well as the safety information for other switches that connect to or support the switch.

The N2128PX-ON model has one internal power supply. The power receptacle is on the rear panel.

AC and DC Power Connection

- 1 Make sure that the switch console port is connected to a VT100 terminal or VT100 terminal emulator via the RJ-45 to DB-9 female cable.
- 2 Using a 5-foot (1.5 m) standard power cable with safety ground connected, connect the power cable to the AC main receptacle located on the rear panel.
- 3 Connect the power cable to a grounded AC outlet.
- 4 If you are using a redundant or external DC power supply, such as the Dell Networking RPS720 or Dell Networking MPS1000 (N2128PX-ON only), connect the DC power cable to the DC receptacle located on the rear panel.

Booting the N2128PX-ON Switch

When the power is turned on with the local terminal already connected, the switch goes through a power-on self-test (POST). POST runs every time the switch is initialized and checks hardware components to determine if the switch is fully operational before completely booting. If POST detects a critical problem, the program flow stops. If POST passes successfully, valid firmware is loaded into RAM. POST messages are displayed on the terminal and indicate test success or failure. The boot process runs for approximately 60 seconds.

You can invoke the **Boot** menu after the first part of the POST is completed. From the **Boot** menu, you can perform configuration tasks such as resetting the system to factory defaults, activating the backup image, or recovering a password. For more information about the **Boot** menu functions, refer to the *CLI Reference Guide*.

Performing the N2128PX-ON Initial Configuration

The initial configuration procedure is based on the following assumptions:

- The Dell Networking switch was never configured before.
- The Dell Networking switch booted successfully.
- The console connection was established, and the **Dell Easy Setup Wizard** prompt appears on the screen of a VT100 terminal or terminal equivalent.

The initial switch configuration is performed through the console port. After the initial configuration, you can manage the switch from the already-connected console port or remotely through an interface defined during the initial configuration.



NOTE: The switch is not configured with a default user name, password, or IP address.

Before setting up the initial configuration of the switch, obtain the following information from your network administrator:

- The IP address to be assigned to the management interface.
- The IP subnet mask for the network.
- The IP address of the management interface default gateway.

These settings are necessary to allow the remote management of the switch through Telnet (Telnet client) or HTTP (Web browser).

Enabling Remote Management

On the N2128PX-ON/N3132PX-ON switches, you can use any of the switch ports on the front panel for in-band management. By default, all in-band ports are members of VLAN 1.

The **Dell Easy Setup Wizard** includes prompts to configure network information for the VLAN 1 interface on the N2128PX-ON switch. You can assign a static IP address and subnet mask or enable DHCP and allow a network DHCP server to assign the information.

Refer to the *CLI Reference Guide* for commands to configure network information.

Initial Configuration Procedure

Perform the initial configuration by using the **Dell Easy Setup Wizard** or by using the CLI. The wizard automatically starts when the switch configuration file is empty. You can exit the wizard at any point by entering [ctrl+z], but all configuration settings specified will be discarded, and the switch will use the default values.



NOTE: If you do not run the **Dell Easy Setup Wizard** or do not respond to the initial Easy Setup Wizard prompt within 60 seconds, the switch enters CLI mode. You must reset the switch with an empty startup configuration in order to rerun the **Dell Easy Setup Wizard**.

For more information about performing the initial configuration by using the CLI, refer to the *CLI Reference Guide*. This *Getting Started Guide* shows how to use the **Dell Easy Setup Wizard** for initial switch configuration. The wizard sets up the following configuration on the switch:

- Establishes the initial privileged user account with a valid password. The wizard configures one privileged user account during the setup.
- Enables CLI login and HTTP access to use the local authentication setting only.
- Sets up the IP address for the VLAN 1 routing interface, of which all in-band ports are members.
- Sets up the SNMP community string to be used by the SNMP manager at a given IP address. You may choose to skip this step if SNMP management is not used for this switch.
- Allows you to specify the network management system IP address or permit management access from all IP addresses.
- Configures the default gateway IP address for the VLAN 1 interface.

Example Session

This section describes a **Dell Easy Setup Wizard** session. The following values are used by the example session:

- The SNMP community string to be used is **public**.
- The network management system (NMS) IP address is **10.1.2.100**.
- The user name is **admin**, and the password is **admin123**.
- The IP address for the VLAN 1 routing interface is **10.1.1.200** with a subnet mask of **255.255.255.0**.
- The default gateway is **10.1.1.1**.

The setup wizard configures the initial values as defined above. After completing the wizard, the switch is configured as follows:

- SNMPv2 is enabled and the community string is set up as defined above. SNMPv3 is disabled by default.
- The admin user account is set up as defined.
- A network management system is configured. From the management station, you can access the SNMP, HTTP, and CLI interfaces. You may also choose to allow all IP addresses to access these management interfaces by choosing the (0.0.0.0) IP address.
- An IP address is configured for the VLAN 1 routing interface.
- A default gateway address is configured.



NOTE: In the following example, the possible user options or default values are enclosed in []. If you press <Enter> with no options defined, the default value is accepted. Help text is in parentheses.

Dell Easy Setup Wizard Console Example

The following example contains the sequence of prompts and responses associated with running an example **Dell Easy Setup Wizard** session, using the input values listed earlier.

After the switch completes the POST and is booted, the following dialog appears:

```
Unit 1 - Waiting to select management unit)>
```

```
_____Dell SupportAssist EULA_____
```

```
I accept the terms of the license agreement. You can reject the license agreement by configuring this command 'eula-consent support-assist reject'.
```

```
By installing SupportAssist, you allow Dell to save your contact information (e.g. name, phone number and/or email address) which would be used to provide technical support for your Dell products and services Dell may use the information for providing recommendations to improve your IT infrastructure. Dell SupportAssist also collects and stores machine diagnostic information, which may include but is not limited to configuration information, user supplied contact information, names of data volumes, IP addresses, access control lists, diagnostics & performance information, network configuration information, host/server configuration & performance information and related data (Collected Data) and transmits this information to Dell. By downloading SupportAssist and agreeing to be bound by these terms and the Dell end user license agreement, available at: http://www.dell.com/aeula, you agree to allow Dell to provide remote monitoring services of your IT environment and you give Dell the right to collect the Collected Data in accordance with Dell's Privacy Policy, available at: http://www.dell.com/privacypolicycountryspecific, in order to enable the performance of all of the various functions of SupportAssist during your entitlement to
```

receive related repair services from Dell. You further agree to allow Dell to transmit and store the Collected Data from SupportAssist in accordance with these terms. You agree that the provision of SupportAssist may involve international transfers of data from you to Dell and/or to Dell's affiliates, subcontractors or business partners. When making such transfers, Dell shall ensure appropriate protection is in place to safeguard the Collected Data being transferred in connection with SupportAssist. If you are downloading SupportAssist on behalf of a company or other legal entity, you are further certifying to Dell that you have appropriate authority to provide this consent on behalf of that entity. If you do not consent to the collection, transmission and/or use of the Collected Data, you may not download, install or otherwise use SupportAssist.

_____AeroHive HiveManager NG EULA_____

This switch includes a feature that enables it to work with HiveManager (an optional management suite), by sending the switch's service tag number and IP Address to HiveManager to authenticate your entitlement to use HiveManager. If you wish to disable this feature, you should run command 'eula-consent hiveagent reject' immediately upon powering up the switch for the first time, or at any time thereafter.

Applying Global configuration, please wait...

Welcome to Dell Easy Setup Wizard

The setup wizard guides you through the initial switch configuration, and gets you up and running as quickly as possible. You can skip the setup wizard, and enter CLI mode to manually configure the switch. You must respond to the next question to run the setup wizard within 60 seconds, otherwise the system will continue

with normal operation using the default system configuration. Note: You can exit the setup wizard at any point by entering [ctrl+z].

Would you like to run the setup wizard (you must answer this question within 60 seconds)? [Y/N] **y**

Step 1:

The system is not set up for SNMP management by default. To manage the switch using SNMP (required for Dell Network Manager) you can

- . Set up the initial SNMP version 2 account now.
- . Return later and set up other SNMP accounts. (For more information on setting up an SNMP version 1 or 3 account, see the user documentation).

Would you like to set up the SNMP management interface now? [Y/N] **y**

To set up the SNMP management account you must specify the management system IP address and the "community string" or password that the particular management system uses to access the switch. The wizard automatically assigns the highest access level [Privilege Level 15] to this account. You can use Dell Network Manager or other management interfaces to change this setting, and to add additional management system information later. For more information on adding management systems, see the user documentation.

To add a management station:

Please enter the SNMP community string to be used.

[public]: **public**

 **NOTE:** If it is configured, the default access level is set to the highest available access for the SNMP management interface. Initially only SNMPv2 will be activated. SNMPv3 is disabled until you return to configure security access for SNMPv3 (e.g. engine ID, view, etc.).

Please enter the IP address of the Management System (A.B.C.D) or wildcard (0.0.0.0) to manage from any Management Station. [0.0.0.0]: **10.1.2.100**

Step 2:

Now we need to set up your initial privilege (Level 15) user account. This account is used to login to the CLI and Web interface. You may set up other accounts and change privilege levels later. For more information on setting up user accounts and changing privilege levels, see the user documentation.

To set up a user account:

```
Please enter the user name. [root]:admin
Please enter the user password: *****
Please reenter the user password: *****
```

Step 3:

Next, an IP address is set up on the VLAN 1 routing interface.

You can use the IP address to access the CLI, Web interface, or SNMP interface of the switch.

To access the switch through any Management Interface you can

- . Set up the IP address for the Management Interface.
- . Set up the default gateway if IP address is manually configured on the routing interface.

Step 4:

```
Would you like to set up the VLAN1 routing interface now? [Y/N] y
```

```
Please enter the IP address of the device (A.B.C.D) or enter "DHCP" (without the quotes) to automatically request an IP address from the network DHCP server:  
10.1.1.200
```

```
Please enter the IP subnet mask (A.B.C.D or /nn):  
255.255.255.0
```

Step 5:

Finally, set up the default gateway. Please enter the IP address of the gateway from which this network is reachable. [0.0.0.0]: **10.1.1.1**

This is the configuration information that has been collected:

```
SNMP Interface = "public"@10.1.2.100
User Account setup = admin
Password = *****
VLAN1 Router Interface IP = 10.1.1.200 255.255.255.0
Default Gateway = 10.1.1.1
```

Step 6:

If the information is correct, please enter (Y) to save the configuration and copy the settings to the start-up configuration file. If the information is incorrect, enter (N) to discard the configuration and restart the wizard: [Y/N] **y**

Thank you for using the Dell Easy Setup Wizard. You will now enter CLI mode.

Applying Interface configuration, please wait...

Next Steps

After completing the initial configuration described in this section, connect any of the front-panel switch ports to a production network for in-band remote management.

If you specified DHCP for the VLAN 1 management interface IP address, the interface will acquire its IP address from a DHCP server on the network. To discover the dynamically assigned IP address, use the console port connection to issue the following command:

- For the VLAN 1 routing interface, enter **show ip interface**.

To access the Dell OpenManage Switch Administrator interface, enter the VLAN 1 management interface IP address into the address field of a Web browser. For remote management access to the CLI, enter the VLAN 1 management interface IP address into a Telnet or SSH client. Alternatively, continue to use the console port for local CLI access to the switch.

Your N2128PX-ON switch supports basic switching features such as VLANs and spanning tree protocol. Use the Web-based management interface or the CLI to configure the features your network requires. For information about how to configure the switch features, refer to the *User Configuration Guide* or *CLI Reference Guide* available on the support site: dell.com/support.

N3132PX-ON Hardware Overview

This section contains information about device characteristics and modular hardware configurations for the Dell Networking N3132PX-ON switch.

Power Consumption for N3132PX-ON PoE Switches

Table 1-5 shows the power consumption data for N3132PX-ON switches. System power consumption is 175W. PoE power budget is 500W for one 715W power supply.

Table 1-5. Power Consumption for N3132PX-ON Switches

Model	Input Voltage	Power Supply Configuration	Maximum Steady Current Consumption (A)	Maximum Steady Power (W)
N3132PX-ON	100V/60Hz	One 715W	6.47A	647.3W
	110V/60Hz	One 715W	5.79A	636.1W
	120V/60Hz	One 715W	5.12A	611.9W
	220V/50Hz	One 715W	2.85A	621.7W
	240V/50Hz	One 715W	2.62A	618.7W

Table 1-6 shows PoE power budget 1200W for two 715W power supplies.

Table 1-6. PoE Power Budget: 1200W for Two 715W Power Supplies

Model	Input Voltage	Power Supply Configuration	Maximum Steady Current Consumption (A)	Maximum Steady Power (W)
N3132PX-ON	100V/60Hz	Two 715W	14.37A	1429.8W
	110V/60Hz	Two 715W	12.95A	1417.6W
	120V/60Hz	Two 715W	11.78A	1409.1W
	220V/50Hz	Two 715W	6.35A	1374.8W
	240V/50Hz	Two 715W	5.84A	1372.5W

Table 1-7 shows PoE power budget 750W for one 1100W power supply.

Table 1-7. PoE Power Budget: 750W for One 1100W Power Supply

Model	Input Voltage	Power Supply Configuration	Maximum Steady Current Consumption (A)	Maximum Steady Power (W)
N3132PX-ON	100V/60Hz	One 1100W	9.41A	937.1W
	110V/60Hz	One 1100W	8.48A	929.7W
	120V/60Hz	One 1100W	7.69A	918.3W
	220V/50Hz	One 1100W	4.16A	904.3W
	240V/50Hz	One 1100W	3.81A	902.3W

Table 1-8 shows PoE power budget 1700W for two 1100W power supplies.

Table 1-8. PoE Power Budget: 1700W for Two 1100W Power Supplies

Model	Input Voltage	Power Supply Configuration	Maximum Steady Current Consumption (A)	Maximum Steady Power (W)
N3132PX-ON	100V/60Hz	Two 1100W	19.16A	1911.2W
	110V/60Hz	Two 1100W	17.24A	1892W
	120V/60Hz	Two 1100W	15.68A	1873W
	220V/50Hz	Two 1100W	8.37A	1819W
	240V/50Hz	Two 1100W	7.7A	1819.2W

Table 1-9 shows PoE power budget 1440W for one 1100W + one 715W power supplies.

Table 1-9. PoE Power Budget: 1440W for One 1100W + One 715W Power Supplies

Model	Input Voltage	Power Supply Configuration	Maximum Steady Current Consumption (A)	Maximum Steady Power (W)
N3132PX-ON	100V/60Hz	1100W + 715W	17.51A	1748W
	110V/60Hz	1100W + 715W	15.7A	1722.3W
	120V/60Hz	1100W + 715W	14.36A	1704.2W
	220V/50Hz	1100W + 715W	7.63A	1663.1W
	240V/50Hz	1100W + 715W	6.99A	1656.3W

Ventilation System

Two fans cool the N3132PX-ON switches in a single Field Replaceable Unit (FRU). The N3132PX-ON switches additionally have a fan in each internal power supply.

N3132PX-ON Model Summary

Table 1-10. N3132PX-ON Switch Regulatory Numbers

Marketing Model Name (MMN)	Description	Power Supply Unit (PSU)	Regulatory Model Number (RMN)	Regulatory Type Number (RTN)
N3132PX-ON	24x1G/8x5G/4x10G SFP+/1x Modular Bay/1+1 Redundant Pluggable PSUs/32 PoE 60W ports/1x Removable Fan Module	1100W/ 715W	E06W	E06W003

N3132PX-ON Installation

Rack Mounting a N3132PX-ON Switch

Place the switch on the rack shelf or mount the switch directly into a 19 inch wide, EIA-310-E compliant rack (four-post, two-post, or threaded methods). The Dell ReadyRail system is provided for 1U front-rack, and two-post installations. The ReadyRail system includes two separately packaged rail assemblies.



WARNING: This is a condensed reference. Read the safety instructions in your Safety, Environmental, and Regulatory information booklet before you begin.



NOTE: The illustrations in this document are not intended to represent a specific switch.

Rack Mounting Safety Considerations

- Rack loading—Overloading or uneven loading of racks may result in shelf or rack failure, causing damage to equipment and possible personal injury. Stabilize racks in a permanent location before loading begins. Mount components beginning at the bottom of the rack, then work to the top. Do not exceed your rack load rating.
- Power considerations—Connect only to the power source specified on the unit. When multiple electrical components are installed in a rack, ensure that the total component power ratings do not exceed circuit capabilities. Overloaded power sources and extension cords present fire and shock hazards.
- Elevated ambient temperature—If installed in a closed rack assembly, the operating temperature of the rack environment may be greater than room ambient. Use care not to exceed the 45° C maximum ambient temperature of the switch.
- Reduced air flow—Install the equipment in the rack so that the amount of airflow required for safe operation of the equipment is not compromised.
- Reliable earthing—Maintain reliable earthing of rack-mounted equipment. Pay particular attention to supply connections other than direct connections to the branch circuit, for example: use of power strips.

- Product should not be mounted with the rear panel facing in the downward position.

Installing the Dell ReadyRail System

The ReadyRail rack mounting system is provided to easily configure your rack for installation of your switch. The ReadyRail system can be installed using the 1U tool-less method or one of three possible 1U tooled methods (two-post flush mount, two-post center mount, or four-post threaded).

1U Tool-less Configuration (Four-post Square Hole or Unthreaded Round Hole)

- 1 With the ReadyRail flange ears facing outward, place one rail between the left and right vertical posts. Align and seat the rear flange rail pegs in the rear vertical post flange. In Figure 1-3, item 1 and its extractions illustrate how the pegs appear in both the square and unthreaded round holes.

Figure 1-3. 1U Tool-less Configuration

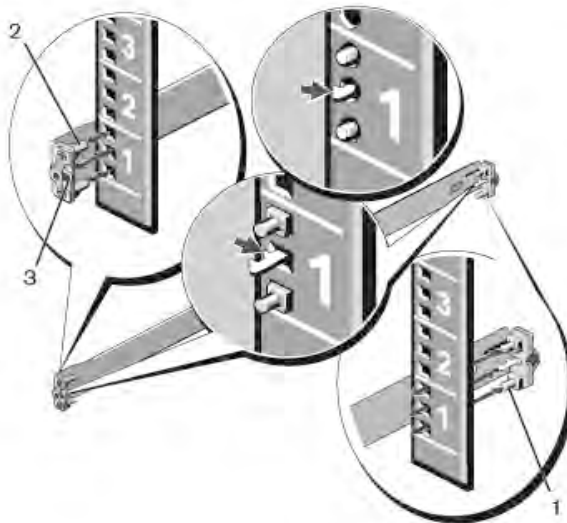

- 2 Align and seat the front flange pegs in the holes on the front side of the vertical post. See Figure 1-3, item 2.
- 3 Repeat this procedure for the second rail.

- 4 To remove each rail, pull on the latch release button on each flange ear and unseat each rail. See Figure 1-3, item 3.

Two-post Flush-mount Configuration

- 1 For this configuration, the castings must be removed from the front side of each ReadyRail assembly. See Figure 1-4, item 1 on page 30. Use a Torx driver to remove the two screws from each front flange ear (on the switch side of the rail) and remove each casting. Retain the castings for future rack requirements. It is not necessary to remove the rear flange castings.

Figure 1-4. Two-post Flush-mount Configuration

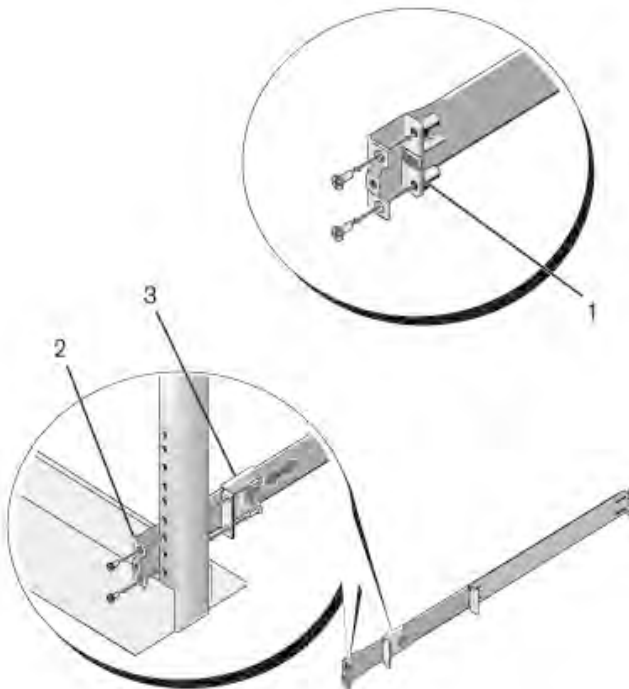

- 2 Attach one rail to the front post flange with two user-supplied screws. See Figure 1-4, item 2.

- 3 Slide the plunger bracket forward against the vertical post and secure the plunger bracket to the post flange with two user-supplied screws. See Figure 1-4, item 3.
- 4 Repeat this procedure for the second rail.

Two-post Center-mount Configuration

- 1 Slide the plunger bracket rearward until it clicks into place and secure the bracket to the front post flange with two user-supplied screws. See Figure 1-5, item 1.

Figure 1-5. Two-post Center-mount Configuration

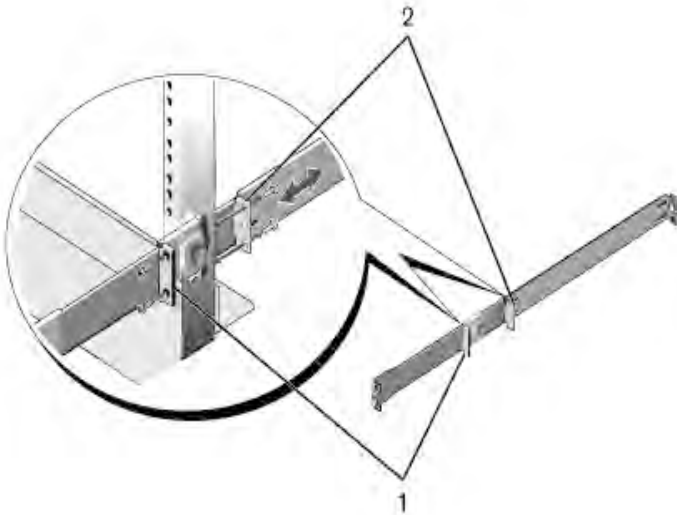

- 2 Slide the back bracket towards the post and secure it to the post flange with two user-supplied screws. See Figure 1-5, item 2.
- 3 Repeat this procedure for the second rail.

Four-post Threaded Configuration

- 1 For this configuration, the flange ear castings must be removed from each end of the ReadyRail assemblies. Use a Torx driver to remove the two screws from each flange ear and remove each casting. See Figure 1-6, item 1. Retain the castings for future rack requirements.
- 2 For each rail, attach the front and rear flanges to the post flanges with two user-supplied screws at each end. See Figure 1-6, item 2.

Figure 1-6. Four-post Threaded Configuration

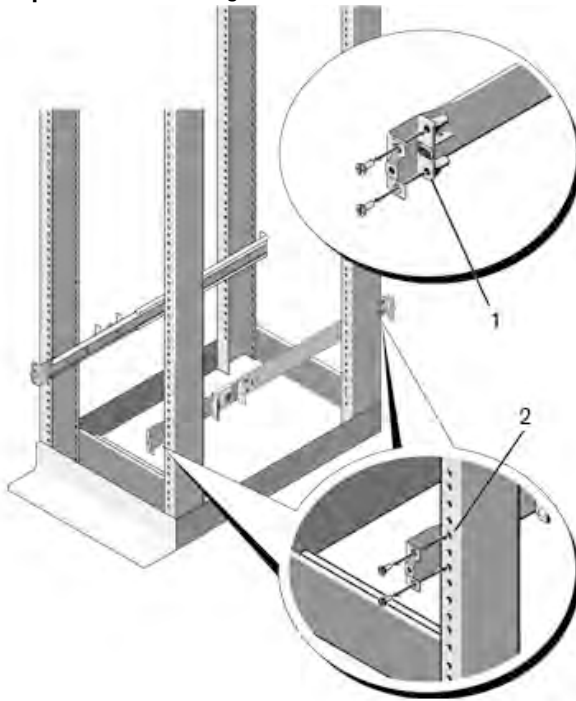

Installing as a Free-standing Switch



NOTE: Dell strongly recommends mounting the switch in a rack.

Install the switch on a flat surface if you are not installing it in a rack. The surface must be able to support the weight of the switch and the switch cables. The switch is supplied with four self-adhesive rubber pads.

- 1 Attach the self-adhesive rubber pads on each location marked on the bottom of the switch.
- 2 Set the switch on a flat surface, and make sure that it has proper ventilation by leaving 5 cm (2 inches) on each side and 13 cm (5 inches) at the back.

Stacking Multiple N3132PX-ON Switches

You can stack N3132PX-ON switches up to 12 switches high using the mini-SAS ports located on the optional stacking expansion module that can be inserted into the rear of the switch. When multiple switches are connected together through the stack ports, they operate as a single unit. Refer to the *User Configuration Guide* and the *CLI Reference Guide* for more information.

Starting and Configuring the N3132PX-ON Switch

The flow chart in Figure 1-7 provides an overview of the steps you use to perform the initial configuration after the switch is unpacked and mounted.

Figure 1-7. Installation and Configuration Flow Chart

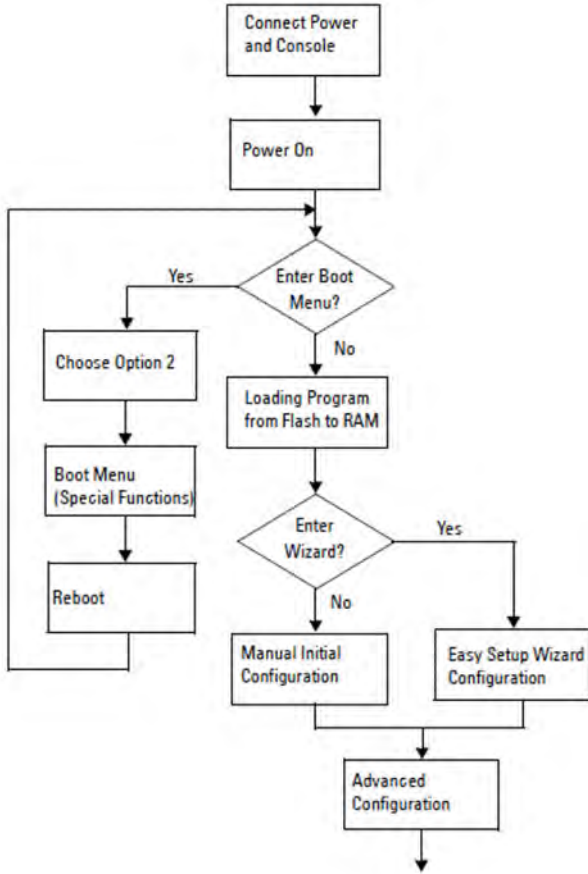

Connecting an N3132PX-ON Switch to a Terminal

After completing all external connections, configure the switch by connecting it to a terminal.



NOTE: Read the Release Notes for this product before proceeding. You can download the Release Notes from the Dell Support website at dell.com/support.



NOTE: Dell recommends that you obtain the most recent version of the user documentation from the Dell Support website at dell.com/support.

To monitor and configure the switch via serial console, use the console port on the front panel of the switch (see Figure 1-8 on page 36) to connect it to a VT100 terminal or to a computer running VT100 terminal emulation software. The console port is implemented as a data terminal equipment (DTE) connector.

The following equipment is required to use the console port:

- VT100-compatible terminal or a computer with a serial port running VT100 terminal emulation software, such as Microsoft HyperTerminal.
- A serial cable (provided) with an RJ-45 connector for the console port and DB-9 connector for the terminal.

Perform the following tasks to connect a terminal to the switch console port:

- 1** Connect the DB-9 connector on the serial cable to the terminal or computer running VT100 terminal emulation software.
- 2** Configure the terminal emulation software as follows:
 - a** Select the appropriate serial port (for example, COM 1) to connect to the console.
 - b** Set the data rate to 115,200 baud.
 - c** Set the data format to 8 data bits, 1 stop bit, and no parity.
 - d** Set the flow control to none.
 - e** Set the terminal emulation mode to VT100.
 - f** Select Terminal keys for Function, Arrow, and Ctrl keys. Make sure that the setting is for Terminal keys (not Microsoft Windows keys).
- 3** Connect the RJ-45 connector on the cable directly to the switch console port. The Dell Networking console port is located on the right side of the front panel and is labeled with a |O|O| symbol, as shown in Figure 1-8.

NOTE: Serial console access to the stack manager is available from any serial port via the local CLI. Only one serial console session at a time is supported.

Figure 1-8. N3132PX-ON Console Port Location

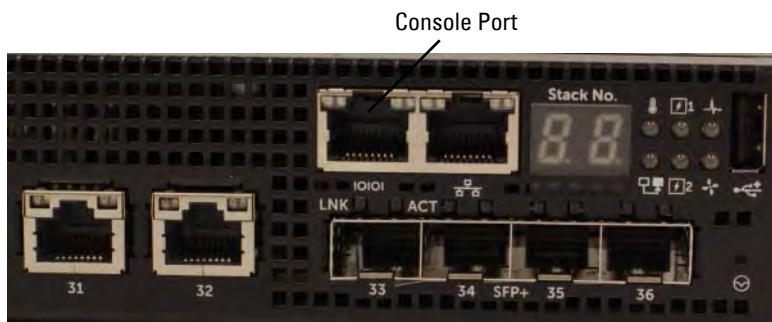

The RJ-45 port to the right of the console port is for out-of-band Ethernet management.

Connecting an N3132PX-ON Switch to a Power Source

CAUTION: Read the safety information in the *Safety and Regulatory Information* manual as well as the safety information for other switches that connect to or support the switch.

The N3132PX-ON switches have two FRU power supplies for redundant or load-sharing operation.

Figure 1-9. Two Redundant Power Supplies on N3132PX-ON



AC and DC Power Connection

- 1 Make sure that the switch console port is connected to a VT100 terminal or VT100 terminal emulator via the RJ-45 to DB-9 female cable.
- 2 Using a 5-foot (1.5 m) standard power cable with safety ground connected, connect the power cable to the AC main receptacle located on the rear panel.
- 3 Connect the power cable to a grounded AC outlet.

Booting the N3132PX-ON Switch

When the power is turned on with the local terminal already connected, the switch goes through a power-on self-test (POST). POST runs every time the switch is initialized and checks hardware components to determine if the switch is fully operational before completely booting. If POST detects a critical problem, the program flow stops. If POST passes successfully, valid firmware is loaded into RAM. POST messages are displayed on the terminal and indicate test success or failure. The boot process runs for approximately 60 seconds.

You can invoke the **Boot** menu after the first part of the POST is completed. From the **Boot** menu, you can perform configuration tasks such as resetting the system to factory defaults, activating the backup image, or recovering a password. For more information about the **Boot** menu functions, refer to the *CLI Reference Guide*.

Performing the N3132PX-ON Initial Configuration

The initial configuration procedure is based on the following assumptions:

- The Dell Networking switch was never configured before.
- The Dell Networking switch booted successfully.
- The console connection was established, and the **Dell Easy Setup Wizard** prompt appears on the screen of a VT100 terminal or terminal equivalent.

The initial switch configuration is performed through the console port. After the initial configuration, you can manage the switch from the already-connected console port or remotely through an interface defined during the initial configuration.



NOTE: The switch is not configured with a default user name or password. The default IP address is set to DHCP for the out-of-band (OOB) port.

Before setting up the initial configuration of the switch, obtain the following information from your network administrator:

- The IP address to be assigned to the management interface.
- The IP subnet mask for the network.
- The IP address of the management interface default gateway.

These settings are necessary to allow the remote management of the switch through Telnet (Telnet client) or HTTP (Web browser).

Enabling Remote Management

The N3132PX-ON switch's front panel contains a Gigabit Ethernet port for OOB management. The OOB port is located to the right of the console port. On the N3132PX-ON switches, use the OOB port or any of the switch ports on the front panel for in-band management. By default, all in-band ports are members of VLAN 1.

The **Dell Easy Setup Wizard** includes prompts to configure network information for the OOB management interface on the N3132PX-ON switch and the VLAN 1 interface on the N3132PX-ON switches. For either management interface, you can assign a static IP address and subnet mask or enable DHCP and allow a network DHCP server to assign the information.

Refer to the *CLI Reference Guide* for commands to configure network information.

Initial Configuration Procedure

Perform the initial configuration by using the **Dell Easy Setup Wizard** or by using the CLI. The wizard automatically starts when the switch configuration file is empty. You can exit the wizard at any point by entering [ctrl+z], but all configuration settings specified will be discarded, and the switch will use the default values.



NOTE: If you do not run the **Dell Easy Setup Wizard** or do not respond to the initial Easy Setup Wizard prompt within 60 seconds, the switch enters CLI mode. You must reset the switch with an empty startup configuration in order to rerun the **Dell Easy Setup Wizard**.

For more information about performing the initial configuration by using the CLI, refer to the *CLI Reference Guide*. This *Getting Started Guide* shows how to use the **Dell Easy Setup Wizard** for initial switch configuration. The wizard sets up the following configuration on the switch:

- Establishes the initial privileged user account with a valid password. The wizard configures one privileged user account during the setup.
- Enables CLI login and HTTP access to use the local authentication setting only.
- Sets up the IP address for the OOB management interface.
- Sets up the IP address for the VLAN 1 routing interface, of which all in-band ports are members.
- Sets up the SNMP community string to be used by the SNMP manager at a given IP address. You may choose to skip this step if SNMP management is not used for this switch.
- Allows you to specify the network management system IP address or permit management access from all IP addresses.
- Configures the default gateway IP address for the VLAN 1 interface.

Example Session

This section describes a **Dell Easy Setup Wizard** session. The following values are used by the example session:

- The SNMP community string to be used is **public**.
- The network management system (NMS) IP address is **10.1.2.100**.
- The user name is **admin**, and the password is **admin123**.
- The OOB management interface uses **DHCP** for IP address assignment.
- The IP address for the VLAN 1 routing interface is **10.1.1.200** with a subnet mask of **255.255.255.0**.
- The default gateway is **10.1.1.1**.

The setup wizard configures the initial values as defined above. After completing the wizard, the switch is configured as follows:

- SNMPv2 is enabled and the community string is set up as defined above. SNMPv3 is disabled by default.
- The admin user account is set up as defined.
- A network management system is configured. From the management station, you can access the SNMP, HTTP, and CLI interfaces.
- DHCP is enabled on the OOB management interface.
- An IP address is configured for the VLAN 1 routing interface.
- A default gateway address is configured.



NOTE: In the following example, the possible user options or default values are enclosed in []. If you press <Enter> with no options defined, the default value is accepted. Help text is in parentheses.

Dell Easy Setup Wizard Console Example

The following example contains the sequence of prompts and responses associated with running an example **Dell Easy Setup Wizard** session, using the input values listed earlier.

After the switch completes the POST and is booted, the following dialog appears:

```
Unit 1 - Waiting to select management unit)>
```

```
_____Dell SupportAssist EULA_____
```

```
I accept the terms of the license agreement. You can  
reject the license agreement by configuring this  
command 'eula-consent support-assist reject'.
```

```
By installing SupportAssist, you allow Dell to save  
your contact information (e.g. name, phone number  
and/or email address) which would be used to provide  
technical support for your Dell products and services  
Dell may use the information for providing  
recommendations to improve your IT infrastructure.  
Dell SupportAssist also collects and stores machine  
diagnostic information, which may include but is not  
limited to configuration information, user supplied  
contact information, names of data volumes, IP  
addresses, access control lists, diagnostics &  
performance information, network configuration  
information, host/server configuration & performance  
information and related data (Collected Data) and  
transmits this information to Dell. By downloading  
SupportAssist and agreeing to be bound by these terms  
and the Dell end user license agreement, available at:  
http://www.dell.com/aeula, you agree to allow Dell to  
provide remote monitoring services of your IT  
environment and you give Dell the right to collect the  
Collected Data in accordance with Dell's Privacy  
Policy, available at:  
http://www.dell.com/privacypolicycountryspecific, in  
order to enable the performance of all of the various  
functions of SupportAssist during your entitlement to
```

receive related repair services from Dell. You further agree to allow Dell to transmit and store the Collected Data from SupportAssist in accordance with these terms. You agree that the provision of SupportAssist may involve international transfers of data from you to Dell and/or to Dell's affiliates, subcontractors or business partners. When making such transfers, Dell shall ensure appropriate protection is in place to safeguard the Collected Data being transferred in connection with SupportAssist. If you are downloading SupportAssist on behalf of a company or other legal entity, you are further certifying to Dell that you have appropriate authority to provide this consent on behalf of that entity. If you do not consent to the collection, transmission and/or use of the Collected Data, you may not download, install or otherwise use SupportAssist.

_____AeroHive HiveManager NG EULA_____

This switch includes a feature that enables it to work with HiveManager (an optional management suite), by sending the switch's service tag number and IP Address to HiveManager to authenticate your entitlement to use HiveManager. If you wish to disable this feature, you should run command 'eula-consent hiveagent reject' immediately upon powering up the switch for the first time, or at any time thereafter.

Applying Global configuration, please wait...

Welcome to Dell Easy Setup Wizard

The setup wizard guides you through the initial switch configuration, and gets you up and running as quickly as possible. You can skip the setup wizard, and enter CLI mode to manually configure the switch. You must respond to the next question to run the setup wizard within 60 seconds, otherwise the system will continue

with normal operation using the default system configuration. Note: You can exit the setup wizard at any point by entering [ctrl+z].

Would you like to run the setup wizard (you must answer this question within 60 seconds)? [Y/N] **y**

Step 1:

The system is not set up for SNMP management by default. To manage the switch using SNMP (required for Dell Network Manager) you can

- . Set up the initial SNMP version 2 account now.
- . Return later and set up other SNMP accounts. (For more information on setting up an SNMP version 1 or 3 account, see the user documentation).

Would you like to set up the SNMP management interface now? [Y/N] **y**

To set up the SNMP management account you must specify the management system IP address and the "community string" or password that the particular management system uses to access the switch. The wizard automatically assigns the highest access level [Privilege Level 15] to this account. You can use Dell Network Manager or other management interfaces to change this setting, and to add additional management system information later. For more information on adding management systems, see the user documentation.

To add a management station:

Please enter the SNMP community string to be used.
[public]: **public**



NOTE: If it is configured, the default access level is set to the highest available access for the SNMP management interface. Initially only SNMPv2 will be activated. SNMPv3 is disabled until you return to configure security access for SNMPv3 (e.g. engine ID, view, etc.).

Please enter the IP address of the Management System (A.B.C.D) or wildcard (0.0.0.0) to manage from any Management Station. [0.0.0.0]: **10.1.2.100**

Step 2:

Now we need to set up your initial privilege (Level 15) user account. This account is used to login to the CLI and Web interface. You may set up other accounts and change privilege levels later. For more information on setting up user accounts and changing privilege levels, see the user documentation.

To set up a user account:

Please enter the user name. [root]:**admin**

Please enter the user password: *********

Please reenter the user password: *********

Step 3:

Next, IP addresses are set up on the OOB (Out-Of-Band) Interface and/or the VLAN 1 routing interface.

You can use these IP addresses to access the CLI, Web interface, or SNMP interface of the switch.

To access the switch through any Management Interface you can

- . Set up the IP address for the Management Interface.

- . Set up the default gateway if IP address is manually configured on both routing and OOB interface.

Would you like to set up the Out-Of-Band interface now? [Y/N] **y**

Please enter the IP address of the device (A.B.C.D) or enter "DHCP" (without the quotes) to automatically request an IP address from the network DHCP server.

[DHCP]: **dhcp**

Step 4:

Would you like to set up the VLAN1 routing interface now? [Y/N] **y**

Please enter the IP address of the device (A.B.C.D) or enter "DHCP" (without the quotes) to automatically request an IP address from the network DHCP server:
10.1.1.200

Please enter the IP subnet mask (A.B.C.D or /nn):
255.255.255.0

Step 5:

Finally, set up the default gateway. Please enter the IP address of the gateway from which this network is reachable. [0.0.0.0]: **10.1.1.1**

This is the configuration information that has been collected:

```
SNMP Interface = "public"@10.1.2.100
User Account setup = admin
Password = *****
Out-of-band IP address = DHCP
VLAN1 Router Interface IP = 10.1.1.200 255.255.255.0
Default Gateway = 10.1.1.1
```

Step 6:

If the information is correct, please enter (Y) to save the configuration and copy the settings to the start-up configuration file. If the information is incorrect, enter (N) to discard the configuration and restart the wizard: [Y/N] **y**

Thank you for using the Dell Easy Setup Wizard. You will now enter CLI mode.

Applying Interface configuration, please wait...

Next Steps

After completing the initial configuration described in this section, connect the OOB port to your management network for out-of-band remote management, or connect any of the front-panel switch ports to a production network for in-band remote management.

If you specified DHCP for the OOB or VLAN 1 management interface IP address, the interface will acquire its IP address from a DHCP server on the network. To discover the dynamically assigned IP address, use the console port connection to issue the following commands:

- For the OOB interface, enter **show ip interface out-of-band**.
- For the VLAN 1 routing interface, enter **show ip interface vlan 1**.

To access the Dell OpenManage Switch Administrator interface, enter the OOB management interface IP address into the address field of a Web browser. For remote management access to the CLI, enter the VLAN 1 management interface IP address into a Telnet or SSH client. Alternatively, you can continue to use the console port for local CLI access to the switch.

The N3132PX-ON switch supports basic switching features such as VLANs and spanning tree protocol. The N3132PX-ON switches also support advanced Layer 3 features such as dynamic routing and multicast. Use the Web-based management interface or the CLI to configure the features your network requires. For information about how to configure the switch features, refer to the *User Configuration Guide* or *CLI Reference Guide* available on the support site: dell.com/support.

NOM Information (Mexico Only)

The following information is provided on the device(s) described in this document in compliance with the requirements of the official Mexican standards (NOM):

Exporter:	Dell Inc. One Dell Way Round Rock, TX 78682
Importer:	Dell Computer de México, S.A. de C.V. Paseo de la Reforma 2620 - 11 ^o Piso Col. Lomas Altas 11950 México, D.F.
Ship to:	Dell Computer de México, S.A. de C.V. al Cuidado de Kuehne & Nagel de México S. de R.L. Avenida Soles No. 55 Col. Peñon de los Baños 15520 México, D.F.
Supply voltage:	Dell Networking N2128PX-ON/N3132PX-ON : 100V–240 VAC
Frequency:	Dell Networking N2128PX-ON/N3132PX-ON : 50–60 Hz
Maximum steady state current consumption:	N2128PX-ON: <ul style="list-style-type: none">• 110V circuit: ~0.80A• 220V circuit: ~0.43A N3132PX-ON: <ul style="list-style-type: none">• 110V circuit: 0.80A• 220V circuit: 0.40A
NOTE: The current shown here is for a single power supply consumption.	

Dell Networking
N2128PX-ON/N3132PX-ON
Commutateurs
Guide de mise en route

Modèles réglementaires : N2128PX-ON/
N3132PX-ON



Remarques, précautions et avertissements



REMARQUE: REMARQUE signale des informations importantes qui vous aident à mieux utiliser votre commutateur.



PRÉCAUTION: ATTENTION vous avertit d'un risque de dommage matériel ou de perte de données et vous indique comment éviter le problème.



AVERTISSEMENT: Un AVERTISSEMENT indique un risque de dommage matériel, de blessure corporelle ou de mort.

Copyright © 2016 Dell Inc. Tous droits réservés. Le présent produit est protégé par les législations américaines et internationales sur le droit d'auteur et la propriété intellectuelle.

Dell™ et le logo Dell sont des marques commerciales de Dell Inc. aux États-Unis et/ou dans d'autres pays. Toutes les autres marques et noms mentionnés dans le présent document sont des marques commerciales de leurs propriétaires respectifs.

Modèles réglementaires N2128PX-0N/N3132PX-0N

Table des matières

1	Introduction	55
	N2128PX-ON Présentation du matériel	55
	Consommation électrique des commutateurs PoE N2128PX-ON	55
	N2128PX-ON Récapitulatif modèles.	57
2	Installation de N2128PX-ON	58
	Montage en rack d'un commutateur N2128PX-ON	58
	Installation dans un rack	58
	Installation en commutateur autonome	59
	Empilage de plusieurs N2128PX-ON commutateurs	59
3	Démarrage et configuration du commutateur N2128PX-ON	60
	Connecter un commutateur N2128PX-ON à un terminal	61
	Connecter un commutateur N2128PX-ON à une source d'alimentation	62
	Connexion alimentation CA et CC	62
	Amorcer le commutateur N2128PX-ON	63

	Réalisation de la configuration initiale du N2128PX-ON	64
	Activer l'administration à distance	64
	Procédure de configuration initiale.	65
	Exemple de session.	66
	Exemple de console de l'Assistant configuration aisée	67
	Étapes suivantes	72
4	N3132PX-ON Présentation du matériel	73
	Consommation électrique des commutateurs PoE N3132PX-ON	73
	Système de ventilation	75
	N3132PX-ON Récapitulatif modèles	76
5	Installation de N3132PX-ON	77
	Montage en rack d'un commutateur N3132PX-ON	77
	Consignes de sécurité de montage en rack	77
	Installation du système Dell ReadyRails	78
	Installation en commutateur autonome	82
	Empilage de plusieurs N3132PX-ON commutateurs.	82
6	Démarrage et configuration du commutateur N3132PX-ON	83
	Connecter un commutateur N3132PX-ON à un terminal	84

Connecter un commutateur N3132PX-ON à une source d'alimentation	85
Connexion alimentation CA et CC	86
Amorcer le commutateur N3132PX-ON	86
Réalisation de la configuration initiale du N3132PX-ON	87
Activer l'administration à distance.	87
Procédure de configuration initiale	88
Exemple de session.	89
Exemple de console de l'Assistant configuration aisée.	90
Étapes suivantes	95
7 Informations NOM (Mexique uniquement)	96

Introduction

Ce document fournit des informations de base concernant les commutateurs Dell® Networking N2128PX-ON/N3132PX-ON, et notamment comment les installer et effectuer la configuration initiale. Pour en savoir plus sur la configuration et la surveillance des fonctions du commutateur, reportez-vous au *Guide de configuration pour l'utilisateur*, disponible sur le site web de support Dell à l'adresse dell.com/support, où vous trouverez les dernières versions de la documentation et des micrologiciels.



REMARQUE : Il est fortement recommandé aux administrateurs des commutateurs de veiller à ce que les commutateurs Dell Networking soient toujours équipés de la version la plus récente de DNOS, le système d'exploitation Dell Networking. Dell Networking améliore en permanence les caractéristiques et les fonctionnalités de DNOS en tenant compte des commentaires émis par les clients. Pour les infrastructures critiques, il est recommandé d'initialiser la nouvelle version dans une partie non critique du réseau afin de vérifier la configuration et le fonctionnement de ce dernier avec la nouvelle version de DNOS.

N2128PX-ON Présentation du matériel

Cette section contient des informations relatives aux caractéristiques de l'appareil et aux configurations matérielles modulaires du commutateur Dell Networking N2128PX-ON.

Consommation électrique des commutateurs PoE N2128PX-ON

Le Tableau 1-1 détaille la consommation électrique des commutateurs N2128PX-ON PoE. La consommation électrique du système est de 90 watts (W). Le bilan de puissance de PoE est de 800W pour le bloc d'alimentation principal (PSU).

Tableau 1-1. Consommation électrique des commutateurs PoE N2128PX-ON

Modèle	Tension d'entrée	Configuration de l'alimentation électrique	Consommation maximale de courant constant (en A)	Puissance constante maximale (en W)
N2128PX-ON	100V/60Hz	PSU principal	9,73A	965,5W
	110V/60Hz	PSU principal	8,75A	960,4W
	120V/60Hz	PSU principal	8,03A	958,3W
	220V/50Hz	PSU principal	4,33A	931W
	240V/50Hz	PSU principal	3,97A	928,7W

Le Tableau 1-2 indique la consommation électrique des commutateurs N2128PX-ON PoE fonctionnant uniquement à partir du bloc d'alimentation modulaire (MPS). Le bilan de puissance de PoE est de 800W pour le bloc d'alimentation modulaire (MPS).

Tableau 1-2. Consommation électrique des commutateurs N2128PX-ON PoE (+ MPS)

Modèle	Tension d'entrée	Configuration de l'alimentation électrique	Consommation maximale de courant constant (en A)	Puissance constante maximale (en W)
N2128PX-ON	100V/60Hz	MPS	9,92A	986,5W
	110V/60Hz	MPS	8,93A	975,7W
	120V/60Hz	MPS	8,01A	955,4W
	220V/50Hz	MPS	4,44A	945,4W
	240V/50Hz	MPS	4,08A	951,4W

Le Tableau 1-3 indique la consommation électrique des commutateurs N2128PX-ON PoE. Le bilan de puissance de PoE est de 1600W pour le bloc d'alimentation principal + le bloc d'alimentation modulaire (MPS).

Tableau 1-3. Consommation électrique des commutateurs PoE N2128PX-ON

Modèle	Tension d'entrée	Configuration de l'alimentation électrique	Consommation maximale de courant constant (en A)	Puissance constante maximale (en W)
N2128PX-ON	100V/60Hz	PSU principal + MPS	11,83A	1175W
	110V/60Hz	PSU principal + MPS	10,71A	1169W
	120V/60Hz	PSU principal + MPS	9,84A	1168,9W
	220V/50Hz	PSU principal + MPS	5,4A	1138,4W
	240V/50Hz	PSU principal + MPS	5,93A	1141W

N2128PX-ON Récapitulatif modèles

Tableau 1-4. N2128PX-ON Numéros réglementaires des commutateurs

Nom marketing de modèle (MMN)	Description	Unité d'alimentation (PSU)	Numéro de modèle réglementaire (RMN)	Numéro de type réglementaire (RTN)
N2128PX-ON	24x1G/4x2.5G/2x10G SFP+/2xStacking/24x PoE+/4xPoE 60W Ports	1000W	E05W	E05W003

Installation de N2128PX-ON

Montage en rack d'un commutateur N2128PX-ON

⚠ AVERTISSEMENT: Prenez connaissance des consignes de sécurité exposées dans les *Informations relatives à la réglementation et la sécurité* ainsi que des informations relatives à la sécurité des autres commutateurs qui se connectent au commutateur ou qui le prennent en charge.

Le connecteur d'alimentation CA se trouve sur le panneau arrière du commutateur.

Installation dans un rack

⚠ AVERTISSEMENT: N'utilisez pas les kits de montage en rack pour suspendre le commutateur en dessous d'une table ou d'un bureau ou pour le fixer à un mur.

⚠ PRÉCAUTION: Avant de poursuivre, débranchez tous les câbles du commutateur. Si nécessaire, retirez tous les coussinets auto-adhésifs du dessous du commutateur.

⚠ PRÉCAUTION: Pour monter plusieurs commutateurs dans un rack, montez les commutateurs de bas en haut.

- 1 Placez le support de montage qui vous est fourni sur un côté du commutateur en faisant en sorte que les orifices de montage sur le commutateur s'alignent sur ceux du support de montage. La Figure 1-1 montre où monter les supports.

Figure 1-1. Fixation des supports



- 2 Insérez les boulons fournis dans les orifices de montage et vissez-les avec un tournevis.

- 3 Répétez l'opération pour le support de montage situé de l'autre côté du commutateur.
- 4 Insérez le commutateur dans le rack de 48,26 cm (19 pouces) en faisant en sorte que les orifices de montage sur le commutateur s'alignent sur ceux du rack.
- 5 Fixez le commutateur au rack avec des boulons de rack ou des écrous à cage et leurs boulons avec rondelles (selon le type du rack). Serrez les boulons en commençant par ceux du bas.



PRÉCAUTION: Assurez-vous que les boulons fournis correspondent bien aux orifices préfiletés du rack.



REMARQUE : Assurez-vous que les orifices de ventilation ne sont pas obstrués.

Installation en commutateur autonome



REMARQUE : Dell recommande fortement de monter le commutateur dans un rack.

Si vous ne l'installez pas dans un rack, installez le commutateur sur une surface plane. La surface doit être capable de supporter le poids du commutateur et de ses câbles. Le commutateur est fourni avec quatre coussinets en caoutchouc auto-adhésifs.

- 1 Fixez ces quatre coussinets à chacun des quatre emplacements marqués en bas du commutateur.
- 2 Posez le commutateur sur une surface plane en vous assurant que la ventilation est suffisante : ménagez pour cela 5 cm (2 pouces) de chaque côté et 13 cm (5 pouces) à l'arrière.

Empilage de plusieurs N2128PX-ON commutateurs

Vous pouvez empiler jusqu'à 12 commutateurs N2128PX-ON en vous servant des ports mini-SAS situés à l'arrière des commutateurs. Lorsque plusieurs commutateurs sont connectés ensemble via les ports d'empilage, ils fonctionnent comme une seule et même unité offrant jusqu'à 336 ports sur le panneau avant. La pile fonctionne et est gérée comme une seule et même entité. Pour plus d'informations, reportez-vous au *Guide de configuration pour l'utilisateur* et au *Guide de référence de l'interface CLI*.

Démarrage et configuration du commutateur N2128PX-ON

Le diagramme qui suit donne une vue générale des étapes par lesquelles passer pour effectuer la configuration initiale une fois que le commutateur a été déballé et monté.

Figure 1-2. Diagramme de l'installation et de la configuration

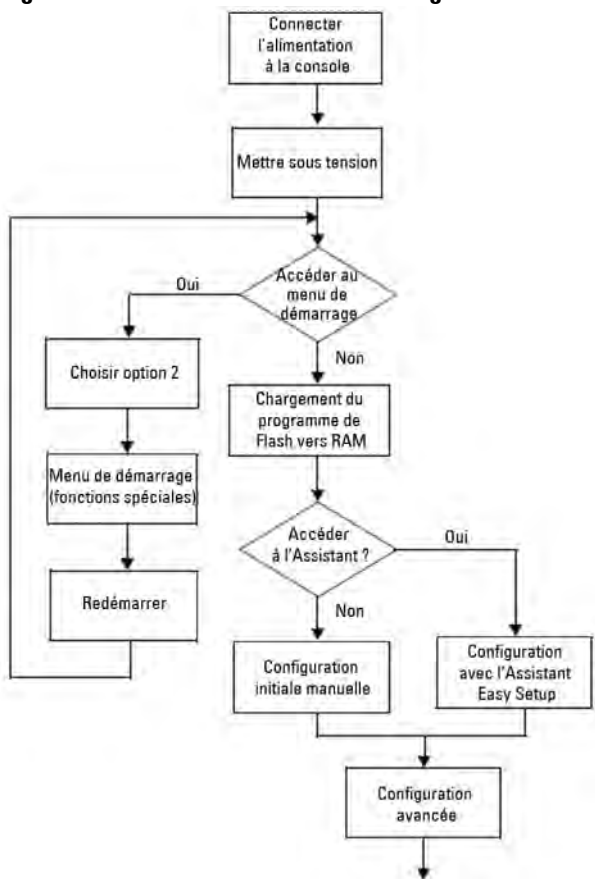

Connecter un commutateur N2128PX-ON à un terminal

Une fois que tous les branchements externes ont été effectués, configurez le commutateur en le connectant à un terminal.



REMARQUE : Avant de continuer, lisez les notes de mise à jour concernant ce produit. Vous pouvez les télécharger à partir du site web du service de support de Dell dell.com/support.



REMARQUE : Dell vous recommande de vous procurer la version la plus récente de la documentation utilisateur, disponible sur le site dell.com/support.

Pour surveiller et configurer le commutateur via la console série, utilisez le port console sur le panneau avant du commutateur pour le connecter à un terminal VT100 ou à un ordinateur exécutant un logiciel d'émulation de terminal VT100. Le port de console est implémenté comme connecteur d'équipement de terminal de données (Data Terminal Equipment – DTE).

Pour utiliser le port de console, vous devez disposer des équipements suivants :

- un terminal compatible avec VT100 ou un ordinateur doté d'un port série exécutant un logiciel d'émulation de terminal VT100, tel que HyperTerminal®
- un câble série (fourni) avec un connecteur RJ-45 pour le port console et un connecteur DB-9 pour le terminal

Pour connecter un terminal au port de console du commutateur, procédez comme suit :

- 1 Connectez le connecteur DB-9 du câble série au terminal ou à l'ordinateur exécutant le logiciel d'émulation de terminal VT100.
- 2 Configurez le logiciel d'émulation de terminal comme suit :
 - a Sélectionnez le port série approprié (par exemple, COM 1) pour établir une connexion à la console.
 - b Réglez le débit de données sur 115 200 bauds.
 - c Réglez le format de données sur 8 bits de données, 1 bit d'arrêt et aucune parité.
 - d Définissez le contrôle de flux sur none (aucun).
 - e Définissez le mode d'émulation de terminal sur VT100.

- f Choisissez l'option Touches de terminal pour les touches de fonction, de direction et Ctrl. Vérifiez que le paramètre correspond bien aux touches de terminal (et non aux touches Microsoft Windows).
 - 3 Connectez le connecteur RJ-45 du câble directement au port de console du commutateur. Le port de console Dell Networking est situé sur le côté droit du panneau avant et est indiqué par le symbole |O|O|.
-  **REMARQUE:** L'accès de la console série au gestionnaire de pile est disponible depuis n'importe quel port série via l'interface CLI locale. Une seule session de console série est possible à la fois.

Connecter un commutateur N2128PX-ON à une source d'alimentation

 **PRÉCAUTION:** Prenez connaissance des consignes de sécurité exposées dans le manuel des *Informations relatives à la réglementation et la sécurité* ainsi que des informations relatives à la sécurité des autres commutateurs qui se connectent au commutateur ou qui le prennent en charge.

Le modèle N2128PX-ON dispose d'un bloc d'alimentation interne. Le réceptacle de l'alimentation se trouve sur le panneau arrière.

Connexion alimentation CA et CC

- 1 Vérifiez que le port de console du commutateur est bien connecté à un terminal VT100 ou à un émulateur de terminal VT100 via le câble femelle RJ-45/DB-9.
- 2 Utilisez un câble d'alimentation standard de 1,5 m (5 pieds) avec mise à la terre que vous brancherez sur le réceptacle CA principal situé sur le panneau arrière.
- 3 Branchez le câble d'alimentation sur une prise électrique CA avec terre.
- 4 Si vous utilisez un bloc d'alimentation CC redondant ou externe, comme le RPS720 Dell Networking ou le MPS1000 Dell Networking (N2128PX-ON uniquement), branchez le câble CC au réceptacle CC situé sur le panneau arrière.

Amorcer le commutateur N2128PX-ON

Lorsque l'alimentation est activée avec le terminal local déjà connecté, le commutateur passe par un auto-test de démarrage (POST). Le POST s'exécute chaque fois que le commutateur est initialisé et il vérifie les composants matériels pour déterminer si le commutateur est totalement opérationnel avant de démarrer complètement. Si le POST détecte un problème critique, le flux du programme s'interrompt. S'il réussit, un micrologiciel valide est chargé en RAM. Des messages du POST s'affichent sur le terminal pour signaler la réussite ou l'échec du test. Le processus d'amorçage dure environ 60 secondes.

Vous pouvez invoquer le menu **Boot** une fois que la première partie du POST s'est effectuée. Dans le menu **Boot**, vous pouvez effectuer des tâches de configuration comme la réinitialisation du système, l'activation de l'image de sauvegarde ou la récupération d'un mot de passe. Pour plus d'informations sur le menu **Boot**, reportez-vous au *Guide de référence de l'interface CLI*.

Réalisation de la configuration initiale du N2128PX-ON

La procédure de configuration initiale présuppose les éléments suivants :

- Le commutateur Dell Networking n'a jamais été configuré.
- Le commutateur Dell Networking a réussi à démarrer.
- La connexion à la console est établie et l'invite de l'**Assistant Dell d'installation facile** s'affiche sur l'écran d'un terminal VT100 ou équivalent.

La configuration initiale du commutateur s'effectue via le port console. Après la configuration initiale, vous pourrez gérer le commutateur à partir du port console déjà connecté ou à distance via une interface qui aura été définie lors de la configuration initiale.



REMARQUE : Le commutateur n'est pas configuré avec un nom d'utilisateur, un mot de passe ou une adresse IP par défaut.

Avant de procéder à la configuration initiale du commutateur, vous devrez obtenir les informations suivantes auprès de votre administrateur réseau :

- l'adresse IP à affecter à l'interface d'administration
- le masque de sous-réseau IP du réseau
- l'adresse IP de la passerelle par défaut de l'interface d'administration

Ces paramètres sont nécessaires pour permettre une administration à distance du commutateur via une connexion Telnet (client Telnet) ou HTTP (navigateur web).

Activer l'administration à distance

Sur les commutateurs N2128PX-ON/N3132PX-ON, il est possible d'utiliser n'importe quel port du panneau avant pour l'administration intrabande. Par défaut, tous les ports intrabande appartiennent au VLAN 1.

L'**Assistant Dell d'installation facile** propose des invites permettant de configurer les informations réseau de l'interface VLAN 1 sur le commutateur N2128PX-ON. Vous pouvez attribuer une adresse IP statique et un masque de sous-réseau ou activer DHCP et permettre à un serveur DHCP d'affecter ces informations.

Pour plus d'informations sur la configuration des informations réseau, reportez-vous au *Guide de référence de l'interface CLI*.

Procédure de configuration initiale

Pour effectuer la configuration initiale, vous pouvez utiliser l'**Assistant Dell d'installation facile** ou passer par l'interface CLI. L'assistant démarre automatiquement lorsque le fichier de configuration du commutateur est vide. Vous pouvez quitter l'assistant à tout moment en entrant [Ctrl+Z], mais tous les paramètres configurés seront ignorés et le commutateur utilisera les valeurs par défaut.



REMARQUE : Si vous n'exécutez pas l'**Assistant Dell d'installation facile** ou si vous ne répondez pas dans les 60 secondes à l'invite initiale de l'Assistant configuration aisée, le commutateur passe en mode CLI. Pour pouvoir réexécuter l'**Assistant Dell d'installation facile**, vous devrez réinitialiser le commutateur avec une configuration de démarrage vide.

Pour plus d'informations sur l'exécution de la configuration initiale à l'aide de l'interface CLI, reportez-vous au *Guide de référence de l'interface CLI*. Ce *Guide de démarrage* décrit la manière d'utiliser l'**Assistant Dell d'installation facile** pour la configuration initiale du commutateur. L'Assistant effectue les opérations suivantes sur le commutateur :

- Il met en place le compte utilisateur privilégié initial et le mot de passe correspondant. L'Assistant configure l'utilisateur privilégié pendant la configuration.
- Il permet à la connexion par CLI et à l'accès par HTTP d'utiliser uniquement le paramètre d'authentification locale.
- Il configure l'adresse IP de l'interface de routage VLAN 1 à laquelle appartiennent tous les ports intrabande.
- Il définit la chaîne de communauté SNMP qui doit être utilisée par le gestionnaire SNMP sur une adresse IP donnée. Vous pouvez ignorer cette étape si le commutateur n'est pas géré via SNMP.
- Il vous permet de spécifier l'adresse IP du système d'administration du réseau ou d'autoriser l'accès à l'administration à partir de toutes les adresses IP.
- Il configure l'adresse IP de la passerelle par défaut pour l'interface VLAN 1.

Exemple de session

Cette section décrit une session **Assistant Dell d'installation facile**. Les valeurs suivantes sont utilisées dans l'exemple de session :

- La chaîne de la communauté SNMP à utiliser est **public**.
- L'adresse IP du système d'administration du réseau (NMS) est **10.1.2.100**.
- Le nom d'utilisateur est **admin** et le mot de passe **admin123**.
- L'adresse IP de l'interface de routage VLAN 1 est **10.1.1.200** avec un masque de sous-réseau **255.255.255.0**.
- La passerelle par défaut est **10.1.1.1**.

L'Assistant utilise les valeurs initiales indiquées ci-dessus pour effectuer la configuration. Une fois que l'Assistant a terminé, le commutateur est configuré comme suit :

- SNMPv2 est activé et la chaîne de communauté est configurée comme défini plus haut. SNMPv3 est désactivé par défaut.
- Le compte utilisateur admin est configuré comme défini plus haut.
- Un système d'administration de réseau est configuré. Depuis la station d'administration, vous pouvez accéder aux interfaces SNMP, HTTP et CLI. En choisissant l'adresse IP (0.0.0.0), vous pouvez également choisir d'autoriser toutes les adresses IP à accéder à ces interfaces d'administration.
- Une adresse IP est configurée pour l'interface de routage VLAN 1.
- Une adresse de passerelle par défaut est configurée.



REMARQUE : Dans l'exemple suivant les options utilisateur possibles ou les valeurs par défaut sont entre crochets []. Appuyer sur <Entrée> sans avoir défini d'options revient à accepter la valeur par défaut. Le texte de l'aide est entre parenthèses.

Exemple de console de l'Assistant configuration aisée

L'exemple suivant contient la séquence d'invites et de réponses d'un exemple de session de l'Assistant Dell d'installation facile. Les valeurs utilisées sont celles indiquées ci-dessus.

Une fois que le commutateur a effectué le POST et qu'il a démarré, le dialogue suivant apparaît :

```
Unit 1 - Waiting to select management unit)>
```

```
_____Dell SupportAssist EULA_____
```

```
I accept the terms of the license agreement. You can
reject the license agreement by configuring this
command 'eula-consent support-assist reject'.
```

```
By installing SupportAssist, you allow Dell to save
your contact information (e.g. name, phone number
and/or email address) which would be used to provide
technical support for your Dell products and services
Dell may use the information for providing
recommendations to improve your IT infrastructure.
Dell SupportAssist also collects and stores machine
diagnostic information, which may include but is not
limited to configuration information, user supplied
contact information, names of data volumes, IP
addresses, access control lists, diagnostics &
performance information, network configuration
information, host/server configuration & performance
information and related data (Collected Data) and
transmits this information to Dell. By downloading
SupportAssist and agreeing to be bound by these terms
and the Dell end user license agreement, available at:
http://www.dell.com/aeula, you agree to allow Dell to
provide remote monitoring services of your IT
environment and you give Dell the right to collect the
Collected Data in accordance with Dell's Privacy
Policy, available at:
http://www.dell.com/privacypolicycountryspecific, in
order to enable the performance of all of the various
functions of SupportAssist during your entitlement to
```

receive related repair services from Dell. You further agree to allow Dell to transmit and store the Collected Data from SupportAssist in accordance with these terms. You agree that the provision of SupportAssist may involve international transfers of data from you to Dell and/or to Dell's affiliates, subcontractors or business partners. When making such transfers, Dell shall ensure appropriate protection is in place to safeguard the Collected Data being transferred in connection with SupportAssist. If you are downloading SupportAssist on behalf of a company or other legal entity, you are further certifying to Dell that you have appropriate authority to provide this consent on behalf of that entity. If you do not consent to the collection, transmission and/or use of the Collected Data, you may not download, install or otherwise use SupportAssist.

_____AeroHive HiveManager NG EULA_____

This switch includes a feature that enables it to work with HiveManager (an optional management suite), by sending the switch's service tag number and IP Address to HiveManager to authenticate your entitlement to use HiveManager. If you wish to disable this feature, you should run command 'eula-consent hiveagent reject' immediately upon powering up the switch for the first time, or at any time thereafter.

Applying Global configuration, please wait...

Welcome to Dell Easy Setup Wizard

The setup wizard guides you through the initial switch configuration, and gets you up and running as quickly as possible. You can skip the setup wizard, and enter CLI mode to manually configure the switch. You must respond to the next question to run the setup wizard within 60 seconds, otherwise the system will continue

with normal operation using the default system configuration. Note: You can exit the setup wizard at any point by entering [ctrl+z].

Would you like to run the setup wizard (you must answer this question within 60 seconds)? [Y/N] **y**

Step 1:

The system is not set up for SNMP management by default. To manage the switch using SNMP (required for Dell Network Manager) you can

- . Set up the initial SNMP version 2 account now.
- . Return later and set up other SNMP accounts. (For more information on setting up an SNMP version 1 or 3 account, see the user documentation).

Would you like to set up the SNMP management interface now? [Y/N] **y**

To set up the SNMP management account you must specify the management system IP address and the "community string" or password that the particular management system uses to access the switch. The wizard automatically assigns the highest access level [Privilege Level 15] to this account. You can use Dell Network Manager or other management interfaces to change this setting, and to add additional management system information later. For more information on adding management systems, see the user documentation.

To add a management station:

Please enter the SNMP community string to be used.
[public]: **public**



REMARQUE : S'il est configuré, le niveau d'accès par défaut est fixé à l'accès le plus élevé disponible pour l'interface d'administration SNMP. Au départ, seul SNMPv2 sera activé. SNMPv3 est désactivé jusqu'à ce que vous reveniez configurer son accès de sécurité (p.ex., ID de moteur, vue, etc.).

Please enter the IP address of the Management System (A.B.C.D) or wildcard (0.0.0.0) to manage from any Management Station. [0.0.0.0]: **10.1.2.100**

Step 2:

Now we need to set up your initial privilege (Level 15) user account. This account is used to login to the CLI and Web interface. You may set up other accounts and change privilege levels later. For more information on setting up user accounts and changing privilege levels, see the user documentation.

To set up a user account:

Please enter the user name. [root]:**admin**

Please enter the user password: *********

Please reenter the user password: *********

Step 3:

Next, an IP address is set up on the VLAN 1 routing interface.

You can use the IP address to access the CLI, Web interface, or SNMP interface of the switch.

To access the switch through any Management Interface you can

- . Set up the IP address for the Management Interface.
- . Set up the default gateway if IP address is manually configured on the routing interface.

Step 4:

Would you like to set up the VLAN1 routing interface now? [Y/N] **y**

Please enter the IP address of the device (A.B.C.D) or enter "DHCP" (without the quotes) to automatically request an IP address from the network DHCP server:

10.1.1.200

Please enter the IP subnet mask (A.B.C.D or /nn):

255.255.255.0

Step 5:

Finally, set up the default gateway. Please enter the IP address of the gateway from which this network is reachable. [0.0.0.0]: **10.1.1.1**

This is the configuration information that has been collected:

SNMP Interface = "public"@10.1.2.100

User Account setup = admin

Password = *****

VLAN1 Router Interface IP = 10.1.1.200 255.255.255.0

Default Gateway = 10.1.1.1

Step 6:

If the information is correct, please enter (Y) to save the configuration and copy the settings to the start-up configuration file. If the information is incorrect, enter (N) to discard the configuration and restart the wizard: [Y/N] **y**

Thank you for using the Dell Easy Setup Wizard. You will now enter CLI mode.

Applying Interface configuration, please wait...

Étapes suivantes

Une fois que vous avez effectué la configuration initiale décrite dans cette section, connectez n'importe quels ports sur le panneau avant du commutateur à un réseau de production pour l'administration intrabande à distance.

Si vous avez spécifié DHCP pour l'adresse IP de l'interface d'administration VLAN 1, cette interface acquerra son adresse IP auprès d'un serveur DHCP du réseau. Pour découvrir l'adresse IP attribuée dynamiquement, utilisez la connexion au port de console pour émettre la commande suivante :

- Pour l'interface de routage VLAN 1, entrez **show ip interface**.

Pour accéder à l'interface Dell OpenManage d'administration du commutateur, entrez l'adresse IP de l'interface d'administration VLAN 1 dans le champ d'adresse d'un navigateur web. Pour l'accès à l'interface CLI de l'administration à distance, entrez l'adresse IP de l'interface d'administration VLAN 1 dans un client Telnet ou SSH. Vous pouvez également continuer à utiliser le port de console pour l'accès de l'interface CLI locale au commutateur.

Votre commutateur N2128PX-ON prend en charge les fonctionnalités de commutation de base comme les VLAN et STP (Spanning Tree Protocol). Utilisez l'interface d'administration web ou CLI pour configurer les fonctionnalités nécessaires à votre réseau. Pour des informations concernant la configuration des fonctionnalités du commutateur, reportez-vous au *Guide de configuration pour l'utilisateur* ou au *Guide de référence de l'interface CLI*, disponible sur le site web de support Dell : dell.com/support.

N3132PX-ON Présentation du matériel

Cette section contient des informations relatives aux caractéristiques de l'appareil et aux configurations matérielles modulaires du commutateur Dell Networking N3132PX-ON.

Consommation électrique des commutateurs PoE N3132PX-ON

Le Tableau 1-5 indique la consommation électrique des commutateurs N3132PX-ON. La consommation électrique du système est de 175W. Le bilan de puissance de PoE est de 500W pour un bloc d'alimentation de 715W.

Tableau 1-5. Consommation électrique des commutateurs N3132PX-ON

Modèle	Tension d'entrée	Configuration de l'alimentation électrique	Consommation maximale de courant constant (en A)	Puissance constante maximale (en W)
N3132PX-ON	100V/60Hz	Un 715W	6,47A	647,3W
	110V/60Hz	Un 715W	5,79A	636,1W
	120V/60Hz	Un 715W	5,12A	611,9W
	220V/50Hz	Un 715W	2,85A	621,7W
	240V/50Hz	Un 715W	2,62A	618,7W

Le Tableau 1-6 indique le bilan de puissance de PoE 1200W pour deux blocs d'alimentation de 715W.

Tableau 1-6. Bilan de puissance PoE : 1200W pour deux blocs d'alimentation de 715W.

Modèle	Tension d'entrée	Configuration de l'alimentation électrique	Consommation maximale de courant constant (en A)	Puissance constante maximale (en W)
N3132PX-ON	100V/60Hz	Deux 715W	14,37A	1429,8W
	110V/60Hz	Deux 715W	12,95A	1417,6W
	120V/60Hz	Deux 715W	11,78A	1409,1W
	220V/50Hz	Deux 715W	6,35A	1374,8W
	240V/50Hz	Deux 715W	5,84A	1372,5W

Le Tableau 1-7 indique le bilan de puissance de PoE 750W pour un bloc d'alimentation de 1100W.

Tableau 1-7. Bilan de puissance PoE : 750W pour un bloc d'alimentation 1100W

Modèle	Tension d'entrée	Configuration de l'alimentation électrique	Consommation maximale de courant constant (en A)	Puissance constante maximale (en W)
N3132PX-ON	100V/60Hz	Un 1100W	9,41A	937,1W
	110V/60Hz	Un 1100W	8,48A	929,7W
	120V/60Hz	Un 1100W	7,69A	918,3W
	220V/50Hz	Un 1100W	4,16A	904,3W
	240V/50Hz	Un 1100W	3,81A	902,3W

Le Tableau 1-8 indique le bilan de puissance de PoE 1700W pour deux blocs d'alimentation de 1100W.

Tableau 1-8. Bilan de puissance PoE : 1700W pour deux blocs d'alimentation de 1100W.

Modèle	Tension d'entrée	Configuration de l'alimentation électrique	Consommation maximale de courant constant (en A)	Puissance constante maximale (en W)
N3132PX-ON	100V/60Hz	Deux 1100W	19,16A	1911,2W
	110V/60Hz	Deux 1100W	17,24A	1892W
	120V/60Hz	Deux 1100W	15,68A	1873W
	220V/50Hz	Deux 1100W	8,37A	1819W
	240V/50Hz	Deux 1100W	7,7A	1819,2W

Le Tableau 1-9 indique le bilan de puissance de PoE 1440W pour un bloc d'alimentation de 1100W + un bloc d'alimentation 715W.

Tableau 1-9. Bilan de puissance PoE : 1440W pour un bloc d'alimentation 1100W + un bloc d'alimentation 715W

Modèle	Tension d'entrée	Configuration de l'alimentation électrique	Consommation maximale de courant constant (en A)	Puissance constante maximale (en W)
N3132PX-ON	100V/60Hz	1100W + 715W	17,51A	1748W
	110V/60Hz	1100W + 715W	15,7A	1722,3W
	120V/60Hz	1100W + 715W	14,36A	1704,2W
	220V/50Hz	1100W + 715W	7,63A	1663,1W
	240V/50Hz	1100W + 715W	6,99A	1656,3W

Système de ventilation

Deux ventilateurs refroidissent les commutateurs N3132PX-ON dans une même unité remplaçable sur site (FRU) Les commutateurs N3132PX-ON ont en plus un ventilateur dans chaque bloc d'alimentation interne.

N3132PX-ON Récapitulatif modèles

Tableau 1-10. N3132PX-ON Numéros réglementaires des commutateurs

Nom marketing de modèle (MMN)	Description	Unité d'alimentation (PSU)	Numéro de modèle réglementaire (RMN)	Numéro de type réglementaire (RTN)
N3132PX-ON	24x1G/8x5G/4x10G SFP+/1x baie modulaire/1+1 PSU connectables redondants/32 ports 60W PoE/1x module de ventilation amovible	1100W/ 715W	E06W	E06W003

Installation de N3132PX-ON

Montage en rack d'un commutateur N3132PX-ON

Placez le commutateur sur l'étagère de rack ou montez-le directement dans un rack (quatre montants, deux montants ou méthodes chaînées) conforme EIA-310-E, large de 19 pouces. Le système Dell ReadyRails est fourni pour les installations à deux montants et de rack avant 1U. Le système ReadyRails comprend deux assemblages de rails packagés séparément.



AVERTISSEMENT: Ceci est une fiche de référence condensée. Veuillez lire les consignes de sécurité qui figurent dans le livret Informations sur la sécurité, l'environnement et les réglementations avant de commencer.



REMARQUE : Les illustrations qui figurent dans ce document ne représentent pas un commutateur spécifique.

Consignes de sécurité de montage en rack

- Chargement de rack – la surcharge ou le chargement irrégulier des racks peut provoquer un dysfonctionnement du rack ou de l'étagère, endommageant l'équipement et créant un risque de blessures corporelles. Stabilisez les racks dans un emplacement permanent avant le démarrage du chargement. Montez les composants en commençant par le bas du rack pour continuer vers le haut. Ne dépassez pas la valeur nominale de votre charge de rack.
- Consignes d'alimentation : effectuez une connexion uniquement vers la source d'alimentation spécifiée sur l'unité. Lorsque plusieurs composants électriques sont installés dans un rack, assurez-vous que la totalité des valeurs nominales d'alimentation des composants ne dépasse pas les capacités de circuit. Les sources d'alimentation et les rallonges surchargées présentent des risques de choc ou d'incendies.
- Température ambiante élevée – s'il est installé dans un assemblage de rack fermé, la température de fonctionnement de l'environnement de rack peut être supérieure à la température ambiante de la pièce. Faites attention à ne pas dépasser la température ambiante maximale de 45°C du commutateur.
- Flux d'air réduit – installez l'équipement dans le rack pour que le flux d'air requis pour un fonctionnement sécurisé de l'équipement ne soit pas compromis.

- Mise à la terre fiable – maintenez une mise à la terre fiable de l'équipement monté en rack. Faites particulièrement attention aux connexions d'alimentation autres que les connexions directes au circuit de dérivation, par exemple, l'utilisation de multiprises.
- Le produit ne doit pas être monté le panneau arrière faisant face au bas.

Installation du système Dell ReadyRails

Le système de montage en rack ReadyRails est fourni pour vous aider à configurer facilement votre rack pour l'installation de votre commutateur. Le système ReadyRails peut être installé à l'aide de la méthode 1U sans outils ou une de trois méthodes possibles 1U avec outils (montage à niveau deux montants, montage centré deux montants ou chaîné deux montants).

Configuration 1U sans outils (trou carré ou trou rond non chaîné quatre montants)

- 1 Les oreilles de collerettes ReadyRails faisant face à l'extérieur, placez un rail entre les montants verticaux de gauche et de droite. Alignez et placez les pinces de rail de collerette arrière dans la collerette du montant vertical arrière. Dans la Figure 1-3, l'élément 1 et ses extractions montrent comment les pinces apparaissent dans les trous ronds non chaînés et les trous carrés.

Figure 1-3. Configuration 1U sans outils

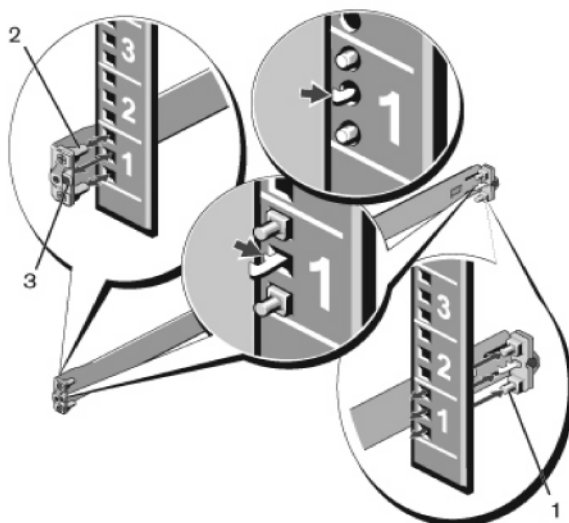

- 2 Aligned et placez les pinces de collerette avant dans les trous du côté avant du montant vertical. Voir la Figure 1-3, élément 2.
- 3 Répétez cette procédure pour le deuxième rail.
- 4 Pour retirer chaque rail, tirez sur le bouton de dégagement du loquet sur chaque oreille de collerette et déplacez chaque rail. Voir la Figure 1-3, élément 3.

Configuration de montage encastré à deux montants

- 1 Pour cette configuration, vous devez retirer les moulages du côté avant de chaque assemblage ReadyRails. Voir la Figure 1-4, élément 1, page 79. Utilisez un tournevis Torx pour retirer les deux vis de chaque oreille de collerette avant (du côté commutateur du rail) et retirez chaque moulage. Gardez les moulages pour de futures exigences de rack. Il n'est pas nécessaire de retirer les moulages de collerette arrière.

Figure 1-4. Configuration de montage encastré à deux montants

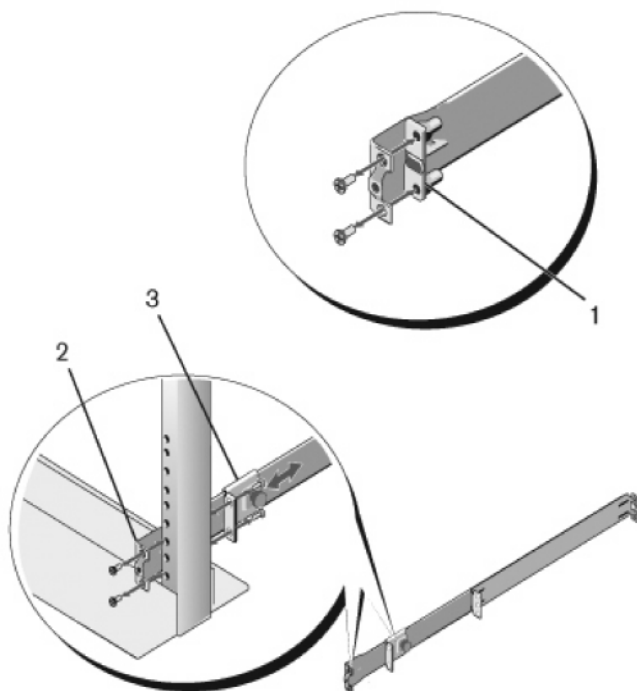

- 2 Attachez un rail à la collerette du montant avant à l'aide de deux vis fournies par l'utilisateur. Voir la Figure 1-4, élément 2.
- 3 Glissez le support de montage en forme de ventouse vers l'avant contre le montant vertical et attachez-le bien à la collerette du montant à l'aide de deux vis fournies par l'utilisateur. Voir la Figure 1-4, élément 3.
- 4 Répétez cette procédure pour le deuxième rail.

Configuration de montage encastré à deux montants

- 1 Glissez le support de montage en forme de ventouse vers l'arrière jusqu'à ce qu'il s'enclenche, puis attachez-le bien à la collerette du montant avant à l'aide de deux vis fournies par l'utilisateur. Voir la Figure 1-5, élément 1.

Figure 1-5. Configuration de montage encastré à deux montants

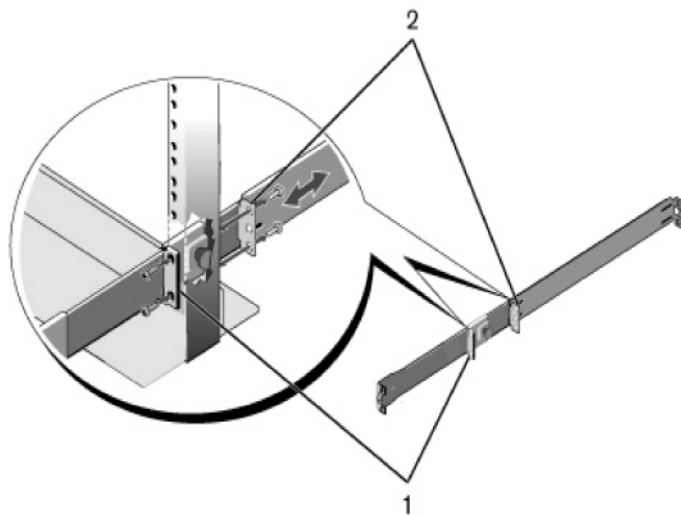

- 2 Glissez le support arrière vers le montant et attachez-le bien à la collerette du montant à l'aide de deux vis fournies par l'utilisateur. Voir la Figure 1-5, élément 2.
- 3 Répétez cette procédure pour le deuxième rail.

Configuration chaînée quatre montants

- 1 Pour cette configuration, vous devez retirer les moulages des oreilles de collerette de chaque extrémité des assemblages ReadyRails. Utilisez un tournevis Torx pour retirer les deux vis de chaque oreille de collerette, puis retirez chaque moulage. Voir la Figure 1-6, élément 1. Gardez les moulages pour de futures exigences de rack.
- 2 Pour chaque rail, attachez les collerettes avant et arrière aux collerettes du montant à l'aide de deux vis fournies par l'utilisateur à chaque extrémité. Voir la Figure 1-6, élément 2.

Figure 1-6. Configuration chaînée quatre montants

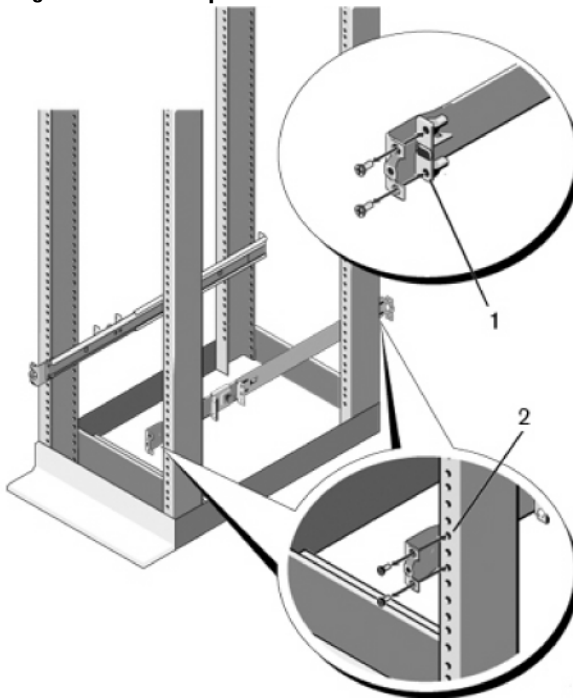

Installation en commutateur autonome



REMARQUE : Dell recommande fortement de monter le commutateur dans un rack.

Si vous ne l'installez pas dans un rack, installez le commutateur sur une surface plane. La surface doit être capable de supporter le poids du commutateur et de ses câbles. Le commutateur est fourni avec quatre coussinets en caoutchouc auto-adhésifs.

- 1 Fixez ces quatre coussinets à chacun des quatre emplacements marqués en bas du commutateur.
- 2 Posez le commutateur sur une surface plane en vous assurant que la ventilation est suffisante : ménégez pour cela 5 cm (2 pouces) de chaque côté et 13 cm (5 pouces) à l'arrière.

Empilage de plusieurs N3132PX-ON commutateurs

Vous pouvez empiler jusqu'à 12 commutateurs N3132PX-ON en vous servant des ports mini-SAS situés sur le module en option d'extension d'empilage qui peut être inséré à l'arrière du commutateur. Lorsque plusieurs commutateurs sont connectés ensemble via les ports d'empilage, ils fonctionnent comme une seule et même unité. Pour plus d'informations, reportez-vous au *Guide de configuration de l'utilisateur* et au *Guide de référence de l'interface CLI*.

Démarrage et configuration du commutateur N3132PX-ON

Le diagramme de la Figure 1-7 donne une vue générale des étapes par lesquelles passer pour effectuer la configuration initiale une fois que le commutateur a été déballé et monté.

Figure 1-7. Diagramme de l'installation et de la configuration

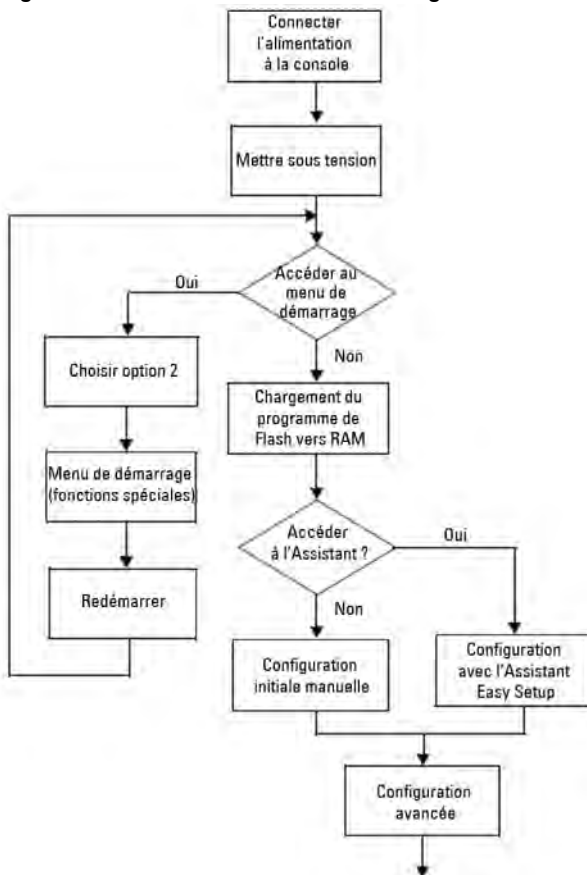

Connecter un commutateur N3132PX-ON à un terminal

Une fois que tous les branchements externes ont été effectués, configurez le commutateur en le connectant à un terminal.



REMARQUE : Avant de continuer, lisez les notes de mise à jour concernant ce produit. Vous pouvez les télécharger à partir du site web du service de support de Dell dell.com/support.



REMARQUE : Dell vous recommande de vous procurer la version la plus récente de la documentation utilisateur, disponible sur le site dell.com/support.

Pour surveiller et configurer le commutateur via la console série, utilisez le port console sur le panneau avant du commutateur (voir Figure 1-8, page 85) pour le connecter à un terminal VT100 ou à un ordinateur exécutant un logiciel d'émulation de terminal VT100. Le port de console est implémenté comme connecteur d'équipement de terminal de données (Data Terminal Equipment – DTE).

Pour utiliser le port de console, vous devez disposer des équipements suivants :

- un terminal compatible avec VT100 ou un ordinateur doté d'un port série et exécutant un logiciel d'émulation de terminal VT100, tel que Microsoft HyperTerminal
- un câble série (fourni) avec un connecteur RJ-45 pour le port console et un connecteur DB-9 pour le terminal

Pour connecter un terminal au port de console du commutateur, procédez comme suit :

- 1 Connectez le connecteur DB-9 du câble série au terminal ou à l'ordinateur exécutant le logiciel d'émulation de terminal VT100.
- 2 Configurez le logiciel d'émulation de terminal comme suit :
 - a Sélectionnez le port série approprié (par exemple, COM 1) pour établir une connexion à la console.
 - b Réglez le débit de données sur 115 200 bauds.
 - c Réglez le format de données sur 8 bits de données, 1 bit d'arrêt et aucune parité.
 - d Définissez le contrôle de flux sur none (aucun).
 - e Définissez le mode d'émulation de terminal sur VT100.

- f Choisissez l'option Touches de terminal pour les touches de fonction, de direction et Ctrl. Vérifiez que le paramètre correspond bien aux touches de terminal (et non aux touches Microsoft Windows).
- 3 Connectez le connecteur RJ-45 du câble directement au port de console du commutateur. Le port de console Dell Networking est situé sur le côté droit du panneau avant et est indiqué par le symbole |O|O| (voir la Figure 1-8).



 **REMARQUE:** L'accès de la console série au gestionnaire de pile est disponible depuis n'importe quel port série via l'interface CLI locale. Une seule session de console série est possible à la fois.

Figure 1-8. Emplacement du port de console du N3132PX-ON

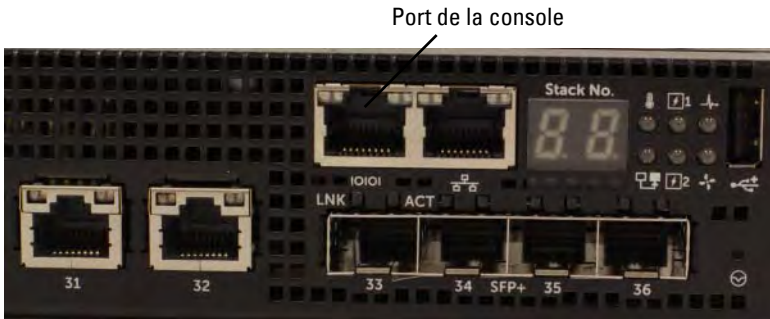

Le port RJ-45 situé à droite du port de console est réservé à l'administration Ethernet hors bande.

Connecter un commutateur N3132PX-ON à une source d'alimentation

 **PRÉCAUTION:** Prenez connaissance des consignes de sécurité exposées dans le manuel des *Informations relatives à la réglementation et la sécurité* ainsi que des informations relatives à la sécurité des autres commutateurs qui se connectent au commutateur ou qui le prennent en charge.

Les commutateurs N3132PX-ON comportent deux blocs d'alimentation FRU pour un fonctionnement redondant ou pour le partage de charge.

Figure 1-9. Deux blocs d'alimentation redondants sur N3132PX-ON.

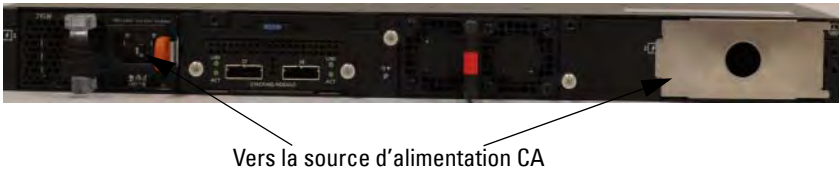

Connexion alimentation CA et CC

- 1 Vérifiez que le port de console du commutateur est bien connecté à un terminal VT100 ou à un émulateur de terminal VT100 via le câble femelle RJ-45/DB-9.
- 2 Utilisez un câble d'alimentation standard de 1,5 m (5 pieds) avec mise à la terre que vous brancherez sur le réceptacle CA principal situé sur le panneau arrière.
- 3 Branchez le câble d'alimentation sur une prise électrique CA avec terre.

Amorcer le commutateur N3132PX-ON

Lorsque l'alimentation est activée avec le terminal local déjà connecté, le commutateur passe par un auto-test de démarrage (POST). Le POST s'exécute chaque fois que le commutateur est initialisé et il vérifie les composants matériels pour déterminer si le commutateur est totalement opérationnel avant de démarrer complètement. Si le POST détecte un problème critique, le flux du programme s'interrompt. S'il réussit, un micrologiciel valide est chargé en RAM. Des messages du POST s'affichent sur le terminal pour signaler la réussite ou l'échec du test. Le processus d'amorçage dure environ 60 secondes.

Vous pouvez invoquer le menu **Boot** une fois que la première partie du POST s'est effectuée. Dans le menu **Boot**, vous pouvez effectuer des tâches de configuration comme la réinitialisation du système, l'activation de l'image de sauvegarde ou la récupération d'un mot de passe. Pour plus d'informations sur le menu **Boot**, reportez-vous au *Guide de référence de l'interface CLI*.

Réalisation de la configuration initiale du N3132PX-ON

La procédure de configuration initiale présuppose les éléments suivants :

- Le commutateur Dell Networking n'a jamais été configuré.
- Le commutateur Dell Networking a réussi à démarrer.
- La connexion à la console est établie et le message de l'**Assistant Dell d'installation facile** s'affiche sur l'écran d'un terminal VT100 ou équivalent.

La configuration initiale du commutateur s'effectue via le port console. Après la configuration initiale, vous pourrez gérer le commutateur à partir du port console déjà connecté ou à distance via une interface qui aura été définie lors de la configuration initiale.



REMARQUE : Le commutateur n'est pas configuré avec un nom d'utilisateur ou un mot de passe par défaut. L'adresse IP par défaut est définie sur DHCP pour le port hors bande (OOB).

Avant de procéder à la configuration initiale du commutateur, vous devez obtenir les informations suivantes auprès de votre administrateur réseau :

- l'adresse IP à affecter à l'interface d'administration
- le masque de sous-réseau IP du réseau
- l'adresse IP de la passerelle par défaut de l'interface d'administration

Ces paramètres sont nécessaires pour permettre une administration à distance du commutateur via une connexion Telnet (client Telnet) ou HTTP (navigateur web).

Activer l'administration à distance

Le panneau avant du commutateur N3132PX-ON contient un port Gigabit Ethernet pour l'administration OOB. Le port OOB est situé à droite du port de console. Sur les commutateurs N3132PX-ON, utilisez le port OOB ou n'importe lequel des ports du panneau avant pour l'administration intrabande. Par défaut, tous les ports intrabande appartiennent au VLAN 1.

L'**Assistant Dell d'installation facile** propose des invites permettant de configurer les informations réseau de l'interface d'administration OOB sur le commutateur N3132PX-ON et l'interface VLAN 1 sur les commutateurs

N3132PX-ON. Pour l'une ou l'autre des interfaces d'administration, vous pouvez attribuer une adresse IP statique et un masque de sous-réseau ou activer DHCP et permettre à un serveur DHCP d'attribuer ces informations.

Pour plus d'informations sur la configuration des informations réseau, reportez-vous au *Guide de référence de l'interface CLI*.

Procédure de configuration initiale

Pour effectuer la configuration initiale, vous pouvez utiliser l'**Assistant Dell d'installation facile** ou passer par l'interface CLI. L'assistant démarre automatiquement lorsque le fichier de configuration du commutateur est vide. Vous pouvez quitter l'assistant à tout moment en entrant [Ctrl+Z], mais tous les paramètres configurés seront ignorés et le commutateur utilisera les valeurs par défaut.



REMARQUE : Si vous n'exécutez pas l'**Assistant Dell d'installation facile** ou si vous ne répondez pas dans les 60 secondes à l'invite initiale de l'Assistant configuration aisée, le commutateur passe en mode CLI. Pour pouvoir réexécuter l'**Assistant Dell d'installation facile**, vous devrez réinitialiser le commutateur avec une configuration de démarrage vide.

Pour plus d'informations sur l'exécution de la configuration initiale à l'aide de l'interface CLI, reportez-vous au *Guide de référence de l'interface CLI*. Ce *Guide de démarrage* décrit la manière d'utiliser l'**Assistant Dell d'installation facile** pour la configuration initiale du commutateur. L'Assistant effectue les opérations suivantes sur le commutateur :

- Il met en place le compte utilisateur privilégié initial et le mot de passe correspondant. L'Assistant configure l'utilisateur privilégié pendant la configuration.
- Il permet à la connexion par CLI et à l'accès par HTTP d'utiliser uniquement le paramètre d'authentification locale.
- Il configure l'adresse IP pour l'interface d'administration OOB.
- Il configure l'adresse IP de l'interface de routage VLAN 1 à laquelle appartiennent tous les ports intrabande.
- Il définit la chaîne de communauté SNMP qui doit être utilisée par le gestionnaire SNMP sur une adresse IP donnée. Vous pouvez ignorer cette étape si le commutateur n'est pas géré via SNMP.

- Il vous permet de spécifier l'adresse IP du système d'administration du réseau ou d'autoriser l'accès à l'administration à partir de toutes les adresses IP.
- Il configure l'adresse IP de la passerelle par défaut pour l'interface VLAN 1.

Exemple de session

Cette section décrit une session **Assistant Dell d'installation facile**. Les valeurs suivantes sont utilisées dans l'exemple de session :

- La chaîne de la communauté SNMP à utiliser est **public**.
- L'adresse IP du système d'administration du réseau (NMS) est **10.1.2.100**.
- Le nom d'utilisateur est **admin** et le mot de passe **admin123**.
- L'interface d'administration OOB utilise **DHCP** pour attribuer les adresses IP.
- L'adresse IP de l'interface de routage VLAN 1 est **10.1.1.200** avec un masque de sous-réseau **255.255.255.0**.
- La passerelle par défaut est **10.1.1.1**.

L'Assistant utilise les valeurs initiales indiquées ci-dessus pour effectuer la configuration. Une fois que l'Assistant a terminé, le commutateur est configuré comme suit :

- SNMPv2 est activé et la chaîne de communauté est configurée comme défini plus haut. SNMPv3 est désactivé par défaut.
- Le compte utilisateur admin est configuré comme défini plus haut.
- Un système d'administration de réseau est configuré. Depuis la station d'administration, vous pouvez accéder aux interfaces SNMP, HTTP et CLI.
- DHCP est activé dans l'interface d'administration OOB.
- Une adresse IP est configurée pour l'interface de routage VLAN 1.
- Une adresse de passerelle par défaut est configurée.



REMARQUE : Dans l'exemple suivant les options utilisateur possibles ou les valeurs par défaut sont entre crochets []. Appuyer sur <Entrée> sans avoir défini d'options revient à accepter la valeur par défaut. Le texte de l'aide est entre parenthèses.

Exemple de console de l'Assistant configuration aisée

L'exemple suivant contient la séquence d'invites et de réponses d'un exemple de session de l'Assistant Dell d'installation facile. Les valeurs utilisées sont celles indiquées ci-dessus.

Une fois que le commutateur a effectué le POST et qu'il a démarré, le dialogue suivant apparaît :

```
Unit 1 - Waiting to select management unit)>
```

```
_____Dell SupportAssist EULA_____
```

```
I accept the terms of the license agreement. You can  
reject the license agreement by configuring this  
command 'eula-consent support-assist reject'.
```

```
By installing SupportAssist, you allow Dell to save  
your contact information (e.g. name, phone number  
and/or email address) which would be used to provide  
technical support for your Dell products and services  
Dell may use the information for providing  
recommendations to improve your IT infrastructure.  
Dell SupportAssist also collects and stores machine  
diagnostic information, which may include but is not  
limited to configuration information, user supplied  
contact information, names of data volumes, IP  
addresses, access control lists, diagnostics &  
performance information, network configuration  
information, host/server configuration & performance  
information and related data (Collected Data) and  
transmits this information to Dell. By downloading  
SupportAssist and agreeing to be bound by these terms  
and the Dell end user license agreement, available at:  
http://www.dell.com/aeula, you agree to allow Dell to  
provide remote monitoring services of your IT  
environment and you give Dell the right to collect the  
Collected Data in accordance with Dell's Privacy  
Policy, available at:  
http://www.dell.com/privacypolicycountryspecific, in  
order to enable the performance of all of the various  
functions of SupportAssist during your entitlement to
```

receive related repair services from Dell. You further agree to allow Dell to transmit and store the Collected Data from SupportAssist in accordance with these terms. You agree that the provision of SupportAssist may involve international transfers of data from you to Dell and/or to Dell's affiliates, subcontractors or business partners. When making such transfers, Dell shall ensure appropriate protection is in place to safeguard the Collected Data being transferred in connection with SupportAssist. If you are downloading SupportAssist on behalf of a company or other legal entity, you are further certifying to Dell that you have appropriate authority to provide this consent on behalf of that entity. If you do not consent to the collection, transmission and/or use of the Collected Data, you may not download, install or otherwise use SupportAssist.

_____AeroHive HiveManager NG EULA_____

This switch includes a feature that enables it to work with HiveManager (an optional management suite), by sending the switch's service tag number and IP Address to HiveManager to authenticate your entitlement to use HiveManager. If you wish to disable this feature, you should run command 'eula-consent hiveagent reject' immediately upon powering up the switch for the first time, or at any time thereafter.

Applying Global configuration, please wait...

Welcome to Dell Easy Setup Wizard

The setup wizard guides you through the initial switch configuration, and gets you up and running as quickly as possible. You can skip the setup wizard, and enter CLI mode to manually configure the switch. You must respond to the next question to run the setup wizard within 60 seconds, otherwise the system will continue

with normal operation using the default system configuration. Note: You can exit the setup wizard at any point by entering [ctrl+z].

Would you like to run the setup wizard (you must answer this question within 60 seconds)? [Y/N] **y**

Step 1:

The system is not set up for SNMP management by default. To manage the switch using SNMP (required for Dell Network Manager) you can

- . Set up the initial SNMP version 2 account now.
- . Return later and set up other SNMP accounts. (For more information on setting up an SNMP version 1 or 3 account, see the user documentation).

Would you like to set up the SNMP management interface now? [Y/N] **y**

To set up the SNMP management account you must specify the management system IP address and the "community string" or password that the particular management system uses to access the switch. The wizard automatically assigns the highest access level [Privilege Level 15] to this account. You can use Dell Network Manager or other management interfaces to change this setting, and to add additional management system information later. For more information on adding management systems, see the user documentation.

To add a management station:

Please enter the SNMP community string to be used.

[public]: **public**



REMARQUE : S'il est configuré, le niveau d'accès par défaut est fixé à l'accès le plus élevé disponible pour l'interface d'administration SNMP. Au départ, seul SNMPv2 sera activé. SNMPv3 est désactivé jusqu'à ce que vous reveniez configurer son accès de sécurité (p.ex., ID de moteur, vue, etc.).

Please enter the IP address of the Management System (A.B.C.D) or wildcard (0.0.0.0) to manage from any Management Station. [0.0.0.0]: **10.1.2.100**

Step 2:

Now we need to set up your initial privilege (Level 15) user account. This account is used to login to the CLI and Web interface. You may set up other accounts and change privilege levels later. For more information on setting up user accounts and changing privilege levels, see the user documentation.

To set up a user account:

```
Please enter the user name. [root]:admin
Please enter the user password: *****
Please reenter the user password: *****
```

Step 3:

Next, IP addresses are set up on the OOB (Out-Of-Band) Interface and/or the VLAN 1 routing interface.

You can use these IP addresses to access the CLI, Web interface, or SNMP interface of the switch.

To access the switch through any Management Interface you can

- . Set up the IP address for the Management Interface.
- . Set up the default gateway if IP address is manually configured on both routing and OOB interface.

```
Would you like to set up the Out-Of-Band interface now? [Y/N] y
```

```
Please enter the IP address of the device (A.B.C.D) or enter "DHCP" (without the quotes) to automatically request an IP address from the network DHCP server.
[DHCP]: dhcp
```

Step 4:

```
Would you like to set up the VLAN1 routing interface now? [Y/N] y
```

Please enter the IP address of the device (A.B.C.D) or enter "DHCP" (without the quotes) to automatically request an IP address from the network DHCP server:

10.1.1.200

Please enter the IP subnet mask (A.B.C.D or /nn):

255.255.255.0

Step 5:

Finally, set up the default gateway. Please enter the IP address of the gateway from which this network is reachable. [0.0.0.0]: **10.1.1.1**

This is the configuration information that has been collected:

SNMP Interface = "public"@10.1.2.100

User Account setup = admin

Password = *****

Out-of-band IP address = DHCP

VLAN1 Router Interface IP = 10.1.1.200 255.255.255.0

Default Gateway = 10.1.1.1

Step 6:

If the information is correct, please enter (Y) to save the configuration and copy the settings to the start-up configuration file. If the information is incorrect, enter (N) to discard the configuration and restart the wizard: [Y/N] **y**

Thank you for using the Dell Easy Setup Wizard. You will now enter CLI mode.

Applying Interface configuration, please wait...

Étapes suivantes

Une fois que vous avez effectué la configuration initiale décrite dans cette section, connectez le port OOB à votre réseau d'administration pour l'administration à distance hors bande ou connectez n'importe quels ports sur le panneau avant du commutateur à un réseau de production pour l'administration intrabande à distance.

Si vous avez spécifié DHCP pour l'adresse IP de l'interface OOB ou pour celle de l'interface d'administration VLAN 1, l'interface acquerra son adresse IP auprès d'un serveur DHCP du réseau. Pour découvrir l'adresse IP attribuée dynamiquement, utilisez la connexion au port de console pour émettre les commandes suivantes :

- Pour l'interface OOB, entrez **show ip interface out-of-band**.
- Pour l'interface de routage VLAN 1, entrez **show ip interface vlan 1**.

Pour accéder à l'interface Dell OpenManage d'administration du commutateur, entrez l'adresse IP de l'interface d'administration OOB dans le champ d'adresse d'un navigateur web. Pour l'accès à l'interface CLI de l'administration à distance, entrez l'adresse IP de l'interface d'administration VLAN 1 dans un client Telnet ou SSH. Vous pouvez également continuer à utiliser le port de console pour l'accès de l'interface CLI locale au commutateur.

Le commutateur N3132PX-ON prend en charge les fonctionnalités de commutation de base comme les VLAN et STP (Spanning Tree Protocol). Les commutateurs N3132PX-ON switches prennent également en charge les fonctionnalités avancées de couche 3 comme le routage dynamique et le multicast. Utilisez l'interface d'administration web ou CLI pour configurer les fonctionnalités nécessaires à votre réseau. Pour des informations concernant la configuration des fonctionnalités du commutateur, reportez-vous au *Guide de configuration pour l'utilisateur* ou au *Guide de référence de l'interface CLI*, disponible sur le site web de support Dell : dell.com/support.

Informations NOM (Mexique uniquement)

Les informations suivantes s'appliquent à ou aux appareils décrits dans ce document conformément à la réglementation des normes officielles mexicaines (NOM) :

Exportateur :	Dell Inc. One Dell Way Round Rock, TX 78682
Importateur :	Dell Computer de México, S.A. de C.V. Paseo de la Reforma 2620 - 11 ^o Piso Col. Lomas Altas 11950 México, D.F.
Adresse de livraison :	Dell Computer de México, S.A. de C.V. al Cuidado de Kuehne & Nagel de México S. de R.L. Avenida Soles No. 55 Col. Peñon de los Baños 15520 México, D.F.
Tension d'alimentation :	N2128PX-ON/N3132PX-ON Dell Networking : 100V–240 VCA
Fréquence :	N2128PX-ON/N3132PX-ON Dell Networking : 50–60 Hz
Consommation maximale de courant constant :	N2128PX-ON : <ul style="list-style-type: none">• Circuit 110V: ~0,80A• Circuit 220V: 0,43A N3132PX-ON : <ul style="list-style-type: none">• Circuit 110V: 0,80A• Circuit 220V: 0,40A
REMARQUE : Le courant indiqué ici concerne la consommation d'un seul bloc d'alimentation.	

Dell Networking
Comutadores N2128PX-ON/
N3132PX-ON

Guia de Noções Básicas

Modelos regulatórios: N2128PX-ON/
N3132PX-ON



Notas, Avisos e Advertências



NOTA: uma NOTA fornece informações importantes para ajudar você a usar melhor o computador.



AVISO: um AVISO indica um potencial de danos ao hardware ou de perda de dados e diz a você como evitar o problema.



ADVERTÊNCIA: uma ADVERTÊNCIA indica um potencial de danos à propriedade, risco de lesões corporais ou mesmo de risco de vida.

Copyright © 2016 Dell Inc. Todos os direitos reservados. Este produto está protegido por leis de copyright e de propriedade intelectual dos EUA e internacionais.

Dell™ e o logotipo Dell são marcas comerciais da Dell Inc. nos Estados Unidos e/ou outras jurisdições. Todas as outras marcas e nomes mencionados aqui podem ser marcas comerciais das respectivas companhias.

Modelos regulatórios N2128PX-ON/N3132PX-ON

Índice

1	Introdução	103
	Visão geral do hardware do N2128PX-ON	103
	Consumo de energia dos comutadores PoE N2128PX-ON	103
	Resumo do modelo N2128PX-ON	105
2	Instalação do N2128PX-ON	106
	Montagem de um comutador N2128PX-ON em rack	106
	Como instalar em um rack	106
	Como instalar um comutador independente	107
	Como empilhar vários comutadores N2128PX-ON	108
3	Como iniciar e configurar o comutador N2128PX-ON	109
	Como conectar um comutador N2128PX-ON a um terminal	110
	Como conectar um comutador N2128PX-ON a uma fonte de energia	111
	Conexão de alimentação CA e CC	111
	Como inicializar o comutador N2128PX-ON	112

	Como executar a configuração inicial do N2128PX-ON	113
	Como habilitar o gerenciamento remoto	113
	Procedimento de configuração inicial	114
	Sessão de exemplo	115
	Exemplo do console do Dell Easy Setup Wizard	116
	Próximas etapas	120
4	Visão geral do hardware do N3132PX-ON	122
	Consumo de energia dos comutadores PoE N3132PX-ON	122
	Sistema de ventilação	124
	Resumo do modelo N3132PX-ON	125
5	Instalação do N3132PX-ON	126
	Montagem de um comutador N3132PX-ON em rack	126
	Considerações sobre segurança da montagem em rack	126
	Instalar o sistema Dell ReadyRail	127
	Como instalar um comutador independente	132
	Como empilhar vários comutadores N3132PX-ON	132
6	Como iniciar e configurar o comutador N3132PX-ON	133
	Como conectar um comutador N3132PX-ON a um terminal	134

Como conectar um comutador N3132PX-ON a uma fonte de energia	135
Conexão de alimentação CA e CC	136
Como inicializar o comutador N3132PX-ON	136
Como executar a configuração inicial do N3132PX-ON	138
Como habilitar o gerenciamento remoto	138
Procedimento de configuração inicial	139
Sessão de exemplo	141
Exemplo do console do Dell Easy Setup Wizard	142
Próximas etapas	146
7 Informações da norma NOM (apenas para o México)	148

Introdução

Este documento fornece informações básicas sobre os comutadores Dell® Networking N2128PX-ON/N3132PX-ON, incluindo a forma de instalar um comutador e executar a configuração inicial. Para obter informações sobre como configurar e monitorar os recursos do comutador, consulte o *User Configuration Guide* (Guia de configuração do usuário), disponível no site de suporte da Dell em dell.com/support (em inglês), para ter acesso às atualizações mais recentes em documentação e firmware.



NOTA: É altamente recomendável que os administradores de comutadores mantenham os comutadores Dell Networking atualizados com a versão mais recente do Dell Networking Operating System (DNOS). A Dell Networking aprimora continuamente os recursos e as funções do DNOS com base em seu feedback como cliente. Em infraestruturas vitais, é recomendável um pré-teste da nova versão em uma parte não vital da rede para verificar a configuração e a operação de rede com a nova versão do DNOS.

Visão geral do hardware do N2128PX-ON

Esta seção contém informações sobre as características do dispositivo e configurações modulares de hardware do comutador Dell Networking N2128PX-ON.

Consumo de energia dos comutadores PoE N2128PX-ON

A Tabela 1-1 descreve o consumo de energia dos comutadores PoE N2128PX-ON. O consumo de energia do sistema é de 90 watts (W). A alocação de energia do PoE é de 800 W da fonte de alimentação principal (PSU).

Tabela 1-1. Consumo de energia dos comutadores PoE N2128PX-ON

Modelo	Tensão de entrada	Configuração da fonte de alimentação	Consumo de corrente constante máxima (A)	Potência constante máxima (W)
N2128PX-ON	100 V/60 Hz	PSU principal	9,73 A	965,5 W
	110 V/60 Hz	PSU principal	8,75 A	960,4 W
	120 V/60 Hz	PSU principal	8,03 A	958,3 W
	220 V/50 Hz	PSU principal	4,33 A	931 W
	240 V/50 Hz	PSU principal	3,97 A	928,7 W

A Tabela 1-2 mostra os dados de consumo de energia dos comutadores N2128PX-ON habilitados para PoE operando somente a partir da fonte de alimentação modular (MPS). A alocação de energia do PoE é de 800 W da MPS.

Tabela 1-2. Dados de consumo de energia dos comutadores PoE N2128PX-ON (+ MPS)

Modelo	Tensão de entrada	Configuração da fonte de alimentação	Consumo de corrente constante máxima (A)	Potência constante máxima (W)
N2128PX-ON	100 V/60 Hz	MPS	9,92 A	986,5 W
	110 V/60 Hz	MPS	8,93 A	975,7 W
	120 V/60 Hz	MPS	8,01 A	955,4 W
	220 V/50 Hz	MPS	4,44 A	945,4 W
	240 V/50 Hz	MPS	4,08 A	951,4 W

A Tabela 1-3 mostra os dados de consumo de energia dos comutadores N2128PX-ON habilitados para PoE. A alocação de energia do PoE é de 1.600 W da fonte de alimentação principal + fonte de alimentação modular (MPS).

Tabela 1-3. Consumo de energia dos comutadores PoE N2128PX-ON

Modelo	Tensão de entrada	Configuração da fonte de alimentação	Consumo de corrente constante máxima (A)	Potência constante máxima (W)
N2128PX-ON	100 V/60 Hz	PSU principal + MPS	11,83 A	1.175 W
	110 V/60 Hz	PSU principal + MPS	10,71 A	1.169 W
	120 V/60 Hz	PSU principal + MPS	9,84 A	1.168,9 W
	220 V/50 Hz	PSU principal + MPS	5,4 A	1.138,4 W
	240 V/50 Hz	PSU principal + MPS	5,93 A	1.141 W

Resumo do modelo N2128PX-ON

Tabela 1-4. Números regulatórios do comutador N2128PX-ON

Nome comercial do modelo (MMN)	Descrição	Unidade da fonte de alimentação (PSU)	Número de modelo regulatório (RMN)	Número de tipo regulatório (RTN)
N2128PX-ON	24x1G/4x2.5G/2x10G SFP+/ 2x de empilhamento/ 24x PoE+/4x portas PoE 60 W	1.000 W	E05W	E05W003

Instalação do N2128PX-ON

Montagem de um comutador N2128PX-ON em rack

 **ADVERTÊNCIA:** leia as informações de segurança nas *Informações de segurança e de normalização* assim como as informações de segurança de outros comutadores que se conectam ou dão suporte ao comutador.

O conector de alimentação CA está localizado no painel traseiro do comutador.

Como instalar em um rack

 **ADVERTÊNCIA:** não use os kits de montagem em rack para suspender o comutador de sob uma mesa ou balcão, ou para fixá-lo em uma parede.

 **AVISO:** desconecte todos os cabos do comutador antes de continuar. Remova todas as bases auto-adesivas da parte inferior do comutador, caso tenham sido colocadas.

 **AVISO:** ao montar vários comutadores em um rack, comece a montagem dos comutadores de baixo para cima.

- 1 Coloque o suporte de montagem em rack fornecido em uma lateral do comutador, certificando-se de que os orifícios de montagem no comutador estão alinhados com os respectivos orifícios de montagem no suporte de montagem em rack. A Figura 1-1 ilustra onde montar os suportes.

Figura 1-1. Como fixar os suportes de montagem



- 2 Insira os parafusos fornecidos nos orifícios de montagem em rack e aperte-os com uma chave de fenda.
- 3 Repita o processo para o suporte de montagem em rack no outro lado do comutador.
- 4 Insira o comutador no rack de 48,26 cm (19 polegadas), certificando-se de que os orifícios de montagem em rack no comutador estão alinhados com os respectivos orifícios de montagem no rack.
- 5 Fixe o comutador ao rack com os parafusos ou porcas gaiola do rack e parafusos de porca gaiola com arruelas (dependendo do tipo de rack que você possui). Aperte os parafusos na parte inferior antes de apertar os parafusos no topo.

⚠ AVISO: certifique-se de que os parafusos do rack fornecidos encaixam nos orifícios pré-rosqueados no rack.

🔧 NOTA: certifique-se de que os orifícios de ventilação não estão obstruídos.

Como instalar um comutador independente

🔧 NOTA: A Dell recomenda expressamente a montagem do comutador em um rack.

Instale o comutador sobre uma superfície plana caso não o esteja instalando em um rack. A superfície deve ser capaz de suportar o peso do comutador e de seus respectivos cabos. O comutador é fornecido com quatro bases de borracha auto-adesivas.

- 1 Fixe as bases de borracha auto-adesivas em cada local marcado na parte inferior do comutador.

- 2 Coloque o comutador sobre uma superfície plana e certifique-se de que há uma ventilação adequada deixando um espaço de 5 cm (2 polegadas) em cada lado e de 13 cm (5 polegadas) na parte de trás.

Como empilhar vários comutadores N2128PX-ON

É possível empilhar até 12 comutadores N2128PX-ON com o uso das portas mini-SAS localizadas na traseira do comutador. Quando vários comutadores são conectados através das portas de empilhamento, eles funcionam como uma única unidade com até 336 portas de painel frontal. A pilha funciona e é gerenciada como uma única entidade. Consulte o *User Configuration Guide* (Guia de configuração do usuário) e o *CLI Reference Guide* (Guia de referência da interface de linha de comando) para obter mais informações.

Como iniciar e configurar o comutador N2128PX-ON

O fluxograma a seguir fornece uma visão geral das etapas usadas para executar a configuração inicial após desembalar e montar o comutador.

Figura 1-2. Fluxograma de instalação e configuração

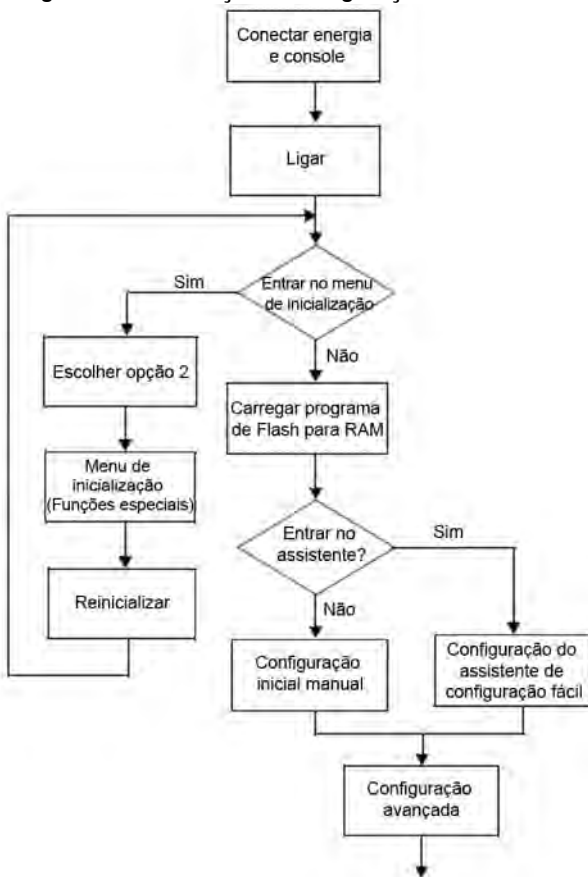

Como conectar um comutador N2128PX-ON a um terminal

Após concluir todas as conexões externas, configure o comutador conectando-o a um terminal.



NOTA: antes de continuar, leia as notas de versão do produto. Você pode fazer o download das notas de versão no site de suporte técnico da Dell em dell.com/support (em inglês).



NOTA: A Dell recomenda que você obtenha a versão mais recente da documentação do usuário do site de suporte técnico da Dell em dell.com/support (em inglês).

Para monitorar e configurar o comutador através do console serial, use a porta de console USB no painel frontal do comutador para conectá-lo a um terminal VT100 ou a um computador executando o software de emulação terminal VT100. A porta de console é implementada como um conector DTE (Data terminal equipment - Equipamento terminal de dados).

Para usar a porta de console, o seguinte equipamento é necessário:

- Terminal compatível com VT100 ou um computador com uma porta serial executando o software de emulação de terminal VT100, como o HyperTerminal®.
- Um cabo serial (fornecido) com um conector RJ-45 para a porta de console e conector DB-9 para o terminal.

Proceda da seguinte forma para conectar o terminal à porta de console do comutador:

- 1** Conecte o conector DB-9 do cabo serial ao terminal ou ao computador que está rodando o software de emulação de terminal VT100.
- 2** Configure o software de emulação de terminal da seguinte forma:
 - a** Selecione a porta serial adequada (por exemplo, COM 1) para ser conectada ao console.
 - b** Configure a taxa de dados para 115.200 bauds.
 - c** Configure o formato de dados em 8 bits de dados, 1 bit de parada e sem paridade.
 - d** Configure o controle de fluxo para nenhum.
 - e** Selecione o modo de emulação de terminal para VT100.

- f Selecione Terminal keys (Teclas do terminal) para as teclas de função, de seta e Ctrl. Certifique-se de que a configuração corresponde à opção Terminal keys (Teclas de terminal) e não a Windows keys (Teclas Windows).
 - 3 Conecte o conector RJ-45 do cabo diretamente à porta de console do comutador. A porta de console do Dell Networking está localizada no lado direito do painel frontal e está identificada com um símbolo |O|O|.
-  **NOTA:** o acesso de console serial ao gerenciador de pilha está disponível a partir de qualquer porta serial por meio da CLI local. Apenas uma sessão de console serial é suportada de cada vez.

Como conectar um comutador N2128PX-ON a uma fonte de energia

 **AVISO:** leia as informações de segurança no manual de *Informações de segurança e de normalização* manual assim como as informações de segurança de outros comutadores que se conectam ou dão suporte ao comutador.

O modelo N2128PX-ON tem uma fonte de alimentação interna.
O receptáculo de alimentação está no painel traseiro.

Conexão de alimentação CA e CC

- 1 Certifique-se de que a porte de console do comutador está conectada a um terminal VT100 ou a um emulador de terminal VT100 por meio do cabo fêmea RJ-45 para DB-9.
- 2 Com o uso de um cabo de alimentação padrão de 1,5 m (5 pés) com aterramento de segurança conectado, conecte o cabo de alimentação ao receptáculo principal de CA localizado no painel traseiro.
- 3 Conecte o cabo de alimentação a uma tomada CA aterrada.
- 4 Caso esteja usando uma fonte de alimentação redundante ou externa de CC, como a Dell Networking RPS720 ou Dell Networking MPS1000 (somente para o N2128PX-ON), conecte o cabo de alimentação CC ao receptáculo de CC localizado no painel traseiro.

Como inicializar o comutador N2128PX-ON

Quando a energia é ligada com o terminal local já conectado, o comutador inicia um teste automático de ligação (POST). O POST é executado sempre que o comutador é inicializado e verifica os componentes de hardware para determinar se o comutador está plenamente operacional antes de efetuar completamente a inicialização. Se o POST detecta um problema crítico, o fluxo de programa é interrompido. Se o POST é executado com êxito, o firmware válido é carregado dentro da RAM. As mensagens de POST são exibidas no terminal e indicam o êxito ou a falha no teste. O processo de inicialização é executado por aproximadamente 60 segundos.

É possível chamar o menu **Boot** (Inicialização) após a primeira parte do POST estar concluída. A partir do menu **Boot** (Inicialização), é possível executar tarefas de configuração como a redefinição do sistema para os padrões de fábrica, a ativação da imagem de backup ou a recuperação de uma senha. Para obter mais informações sobre as funções do menu **Boot** (Inicialização), consulte o *CLI Reference Guide (Guia de referência da interface de linha de comando)*.

Como executar a configuração inicial do N2128PX-ON

O procedimento da configuração inicial está baseado nas seguintes premissas:

- O comutador Dell Networking nunca foi configurado anteriormente.
- O comutador Dell Networking inicializou com êxito.
- A conexão do console foi estabelecida e o prompt do **Dell Easy Setup Wizard** (Assistente de configuração rápida da Dell) aparece na tela de um terminal VT100 ou equivalente.

A configuração inicial do comutador é executada através da porta de console. Após a configuração inicial, é possível gerenciar o comutador da porta de console já conectada ou remotamente através de uma interface definida durante a configuração inicial.



NOTA: o comutador não está configurado com um nome de usuário, senha ou endereço IP padrão.

Antes de definir a configuração inicial do comutador, obtenha as seguintes informações do administrador de rede:

- O endereço IP a ser atribuído à interface de gerenciamento.
- A máscara de sub-rede IP da rede.
- O endereço IP do gateway padrão da interface de gerenciamento.

Estas configurações são necessárias para permitir o gerenciamento remoto do comutador por Telnet (cliente Telnet) ou HTTP (navegador).

Como habilitar o gerenciamento remoto

Nos comutadores N2128PX-ON/N3132PX-ON, é possível usar qualquer uma das portas no painel frontal do comutador para gerenciamento na banda. Por padrão, todas as portas na banda são membros da VLAN 1.

O **Dell Easy Setup Wizard** (Assistente de configuração rápida da Dell) inclui prompts para configurar as informações de rede da interface da VLAN 1 no comutador N2128PX-ON. É possível atribuir um endereço IP estático e máscara de sub-rede ou habilitar DHCP e permitir que um servidor DHCP da rede atribua as informações.

Consulte o *CLI Reference Guide* (Guia de referência da interface de linha de comando) com relação a comandos para configurar as informações de rede.

Procedimento de configuração inicial

Execute a configuração inicial com o uso do **Dell Easy Setup Wizard** (Assistente de configuração rápida da Dell) ou da CLI. O assistente inicia automaticamente quando o arquivo de configuração do comutador está vazio. É possível sair do assistente a qualquer momento ao pressionar [ctrl+z], mas todas as definições de configuração especificadas serão descartadas e o comutador usará os valores padrão.



NOTA: se você não executar o **Dell Easy Setup Wizard** (Assistente de configuração rápida da Dell) ou não responder ao prompt inicial do Easy Setup Wizard dentro de 60 segundos, o comutador entra no modo CLI. É preciso redefinir o comutador com uma configuração de inicialização vazia de forma a executar novamente o **Dell Easy Setup Wizard** (Assistente de configuração rápida da Dell).

Para obter mais informações sobre como executar a configuração inicial com o uso da CLI, consulte o *CLI Reference Guide* (Guia de referência da interface de linha de comando). Este *Guia de Noções Básicas* mostra como usar o **Dell Easy Setup Wizard** (Assistente de configuração rápida da Dell) para efetuar a configuração inicial do comutador. O assistente define a seguinte configuração no comutador:

- Estabelece a conta de usuário com privilégios inicial com uma senha válida. O assistente configura uma única conta de usuário com privilégios durante a configuração.
- Habilita login da CLI e acesso HTTP para usar somente a configuração de autenticação local.
- Define o endereço IP da interface de roteamento da VLAN 1, da qual todas as portas na banda são membros.
- Define a string de comunidade SNMP a ser usada pelo gerente de SNMP em um dado endereço IP. Ignore esta etapa se o gerenciamento de SNMP não for usado para o comutador em questão.
- Permite especificar o endereço IP do sistema de gerenciamento da rede ou autoriza o acesso de gerenciamento a partir de todos os endereços IP.
- Configura o endereço IP do gateway padrão para a interface da VLAN 1.

Sessão de exemplo

Esta seção descreve uma sessão do **Dell Easy Setup Wizard** (Assistente de configuração rápida da Dell). Os valores a seguir serão usados pela sessão de exemplo:

- A cadeia de caracteres da comunidade SNMP a ser usada é **public**.
- O endereço IP do sistema de gerenciamento de rede (NMS) é **10.1.2.100**.
- O nome de usuário é **admin** e a senha é **admin123**.
- O endereço IP para a interface de roteamento da VLAN 1 é **10.1.1.200** com uma máscara de sub-rede igual a **255.255.255.0**.
- O gateway padrão é **10.1.1.1**.

O assistente de configuração atribui os valores iniciais como definido acima. Após concluir o assistente, o comutador está configurado como a seguir:

- SNMPv2 está habilitado e a cadeia de caracteres da comunidade está configurada como definido acima. SNMPv3 está habilitado por padrão.
- A conta de usuário admin está configurada como definido acima.
- Um sistema de gerenciamento de rede está configurado. A partir da estação de gerenciamento, é possível acessar as interfaces de SNMP, HTTP e CLI. É possível optar também por permitir que todos os endereços IP tenham acesso a essas interfaces de gerenciamento ao escolher o endereço IP (0.0.0.0).
- Um endereço IP está configurado para a interface de roteamento da VLAN 1.
- O endereço do gateway padrão está configurado.



NOTA: No exemplo a seguir, as possíveis opções do usuário ou valores padrão estão entre []. Caso você pressione <Enter> sem qualquer opção definida, o valor padrão será aceito. O texto de ajuda se encontra entre parênteses.

Exemplo do console do Dell Easy Setup Wizard

O exemplo a seguir contém a sequência de prompts e as respostas associadas à execução de uma sessão de exemplo do **Dell Easy Setup Wizard** (Assistente de configuração rápida da Dell), usando os valores de entrada listados anteriormente.

Após o computador concluir o POST e ter inicializado, o seguinte diálogo é exibido:

```
Unit 1 - Waiting to select management unit)>
```

```
_____Dell SupportAssist EULA_____
```

```
I accept the terms of the license agreement. You can reject the license agreement by configuring this command 'eula-consent support-assist reject'.
```

```
By installing SupportAssist, you allow Dell to save your contact information (e.g. name, phone number and/or email address) which would be used to provide technical support for your Dell products and services Dell may use the information for providing recommendations to improve your IT infrastructure. Dell SupportAssist also collects and stores machine diagnostic information, which may include but is not limited to configuration information, user supplied contact information, names of data volumes, IP addresses, access control lists, diagnostics & performance information, network configuration information, host/server configuration & performance information and related data (Collected Data) and transmits this information to Dell. By downloading SupportAssist and agreeing to be bound by these terms and the Dell end user license agreement, available at: http://www.dell.com/aeula, you agree to allow Dell to provide remote monitoring services of your IT environment and you give Dell the right to collect the Collected Data in accordance with Dell's Privacy Policy, available at: http://www.dell.com/privacypolicycountryspecific, in order to enable the performance of all of the various
```

functions of SupportAssist during your entitlement to receive related repair services from Dell. You further agree to allow Dell to transmit and store the Collected Data from SupportAssist in accordance with these terms. You agree that the provision of SupportAssist may involve international transfers of data from you to Dell and/or to Dell's affiliates, subcontractors or business partners. When making such transfers, Dell shall ensure appropriate protection is in place to safeguard the Collected Data being transferred in connection with SupportAssist. If you are downloading SupportAssist on behalf of a company or other legal entity, you are further certifying to Dell that you have appropriate authority to provide this consent on behalf of that entity. If you do not consent to the collection, transmission and/or use of the Collected Data, you may not download, install or otherwise use SupportAssist.

_____AeroHive HiveManager NG EULA_____

This switch includes a feature that enables it to work with HiveManager (an optional management suite), by sending the switch's service tag number and IP Address to HiveManager to authenticate your entitlement to use HiveManager. If you wish to disable this feature, you should run command 'eula-consent hiveagent reject' immediately upon powering up the switch for the first time, or at any time thereafter.

Applying Global configuration, please wait...

Welcome to Dell Easy Setup Wizard

The setup wizard guides you through the initial switch configuration, and gets you up and running as quickly as possible. You can skip the setup wizard, and enter CLI mode to manually configure the switch. You must respond to the next question to run the setup wizard within 60 seconds, otherwise the system will continue

with normal operation using the default system configuration. Note: You can exit the setup wizard at any point by entering [ctrl+z].

Would you like to run the setup wizard (you must answer this question within 60 seconds)? [Y/N] **y**

Step 1:

The system is not set up for SNMP management by default. To manage the switch using SNMP (required for Dell Network Manager) you can

- . Set up the initial SNMP version 2 account now.
- . Return later and set up other SNMP accounts. (For more information on setting up an SNMP version 1 or 3 account, see the user documentation).

Would you like to set up the SNMP management interface now? [Y/N] **y**

To set up the SNMP management account you must specify the management system IP address and the "community string" or password that the particular management system uses to access the switch. The wizard automatically assigns the highest access level [Privilege Level 15] to this account. You can use Dell Network Manager or other management interfaces to change this setting, and to add additional management system information later. For more information on adding management systems, see the user documentation.

To add a management station:

Please enter the SNMP community string to be used.

[public]: **public**



NOTA: Caso esteja configurado, o nível de acesso padrão é definido com o máximo nível de acesso disponível para a interface de gerenciamento SNMP. Inicialmente, somente SNMPv2 será ativado. SNMPv3 estará desabilitado até que você retorne a configurar o acesso de segurança de SNMPv3 (por exemplo: engine ID, view, etc.).

Please enter the IP address of the Management System (A.B.C.D) or wildcard (0.0.0.0) to manage from any Management Station. [0.0.0.0]: **10.1.2.100**

Step 2:

Now we need to set up your initial privilege (Level 15) user account. This account is used to login to the CLI and Web interface. You may set up other accounts and change privilege levels later. For more information on setting up user accounts and changing privilege levels, see the user documentation.

To set up a user account:

```
Please enter the user name. [root]:admin
Please enter the user password: *****
Please reenter the user password: *****
```

Step 3:

Next, an IP address is set up on the VLAN 1 routing interface.

You can use the IP address to access the CLI, Web interface, or SNMP interface of the switch.

To access the switch through any Management Interface you can

- . Set up the IP address for the Management Interface.
- . Set up the default gateway if IP address is manually configured on the routing interface.

Step 4:

```
Would you like to set up the VLAN1 routing interface now? [Y/N] y
```

```
Please enter the IP address of the device (A.B.C.D) or enter "DHCP" (without the quotes) to automatically request an IP address from the network DHCP server:  
10.1.1.200
```

```
Please enter the IP subnet mask (A.B.C.D or /nn):  
255.255.255.0
```

Step 5:

Finally, set up the default gateway. Please enter the IP address of the gateway from which this network is reachable. [0.0.0.0]: **10.1.1.1**

This is the configuration information that has been collected:

```
SNMP Interface = "public"@10.1.2.100
User Account setup = admin
Password = *****
VLAN1 Router Interface IP = 10.1.1.200 255.255.255.0
Default Gateway = 10.1.1.1
```

Step 6:

If the information is correct, please enter (Y) to save the configuration and copy the settings to the start-up configuration file. If the information is incorrect, enter (N) to discard the configuration and restart the wizard: [Y/N] **y**

Thank you for using the Dell Easy Setup Wizard. You will now enter CLI mode.

Applying Interface configuration, please wait...

Próximas etapas

Após concluir a configuração inicial descrita nesta seção, conecte qualquer uma das portas do painel frontal do comutador a uma rede de produção para gerenciamento remoto na banda.

Caso tenha especificado DHCP para o endereço IP da interface de gerenciamento da VLAN 1, a interface obterá seu endereço IP de um servidor DHCP na rede. Para descobrir o endereço IP atribuído dinamicamente, use a conexão da porta de console para emitir o seguinte comando:

- Na interface de roteamento da VLAN 1, digite **show ip interface**.

Para ter acesso à interface do Dell OpenManage Switch Administrator, digite o endereço IP da interface de gerenciamento da VLAN 1 no campo de endereço de um navegador da Web. Para acesso de gerenciamento remoto

para a CLI, digite o endereço IP da interface de gerenciamento da VLAN 1 em um cliente Telnet ou SSH. Como alternativa, continue a usar a porta de console para acesso de CLI local ao comutador.

O seu comutador N2128PX-ON suporta recursos de chaveamento básico como VLANs e protocolo de estrutura estendida. Use a interface de gerenciamento baseada na Web ou a CLI para configurar os recursos demandados por sua rede. Para obter informações sobre como configurar os recursos do comutador, consulte o *User Configuration Guide* (Guia de configuração do usuário) ou o *CLI Reference Guide* (Guia de referência da interface de linha de comando), disponíveis no site de suporte: **dell.com/support** (em inglês).

Visão geral do hardware do N3132PX-ON

Esta seção contém informações sobre as características do dispositivo e configurações modulares de hardware do comutador Dell Networking N3132PX-ON.

Consumo de energia dos comutadores PoE N3132PX-ON

A Tabela 1-5 mostra os dados de consumo de energia dos comutadores N3132PX-ON. O consumo de energia do sistema é de 175 W. A alocação de energia do PoE é de 500 W de uma fonte de alimentação de 715 W.

Tabela 1-5. Consumo de energia dos comutadores N3132PX-ON

Modelo	Tensão de entrada	Configuração da fonte de alimentação	Consumo de corrente constante máxima (A)	Potência constante máxima (W)
N3132PX-ON	100 V/60 Hz	Uma de 715 W	6,47 A	647,3 W
	110 V/60 Hz	Uma de 715 W	5,79 A	636,1 W
	120 V/60 Hz	Uma de 715 W	5,12 A	611,9 W
	220 V/50 Hz	Uma de 715 W	2,85 A	621,7 W
	240 V/50 Hz	Uma de 715 W	2,62 A	618,7 W

A Tabela 1-6 mostra a alocação de energia do PoE de 1.200 W de duas fontes de alimentação de 715 W.

Tabela 1-6. Alocação de energia do PoE: 1.200 W de duas fontes de alimentação de 715

Modelo	Tensão de entrada	Configuração da fonte de alimentação	Consumo de corrente constante máxima (A)	Potência constante máxima (W)
N3132PX-ON	100 V/60 Hz	Duas de 715 W	14,37 A	1.429,8 W
	110 V/60 Hz	Duas de 715 W	12,95 A	1.417,6 W
	120 V/60 Hz	Duas de 715 W	11,78 A	1.409,1 W
	220 V/50 Hz	Duas de 715 W	6,35 A	1.374,8 W
	240 V/50 Hz	Duas de 715 W	5,84 A	1.372,5 W

W

A Tabela 1-7 mostra a alocação de energia do PoE de 750 W de uma fonte de alimentação de 1.100 W.

Tabela 1-7. Alocação de energia do PoE: 750 W de uma fonte de alimentação de 1.100

Modelo	Tensão de entrada	Configuração da fonte de alimentação	Consumo de corrente constante máxima (A)	Potência constante máxima (W)
N3132PX-ON	100 V/60 Hz	Uma de 1.100 W	9,41 A	937,1 W
	110 V/60 Hz	Uma de 1.100 W	8,48 A	929,7 W
	120 V/60 Hz	Uma de 1.100 W	7,69 A	918,3 W
	220 V/50 Hz	Uma de 1.100 W	4,16 A	904,3 W
	240 V/50 Hz	Uma de 1.100 W	3,81 A	902,3 W

W

A Tabela 1-8 mostra a alocação de energia do PoE de 1.700 W de duas fontes de alimentação de 1.100 W.

Tabela 1-8. Alocação de energia do PoE: 1.700 W de duas fontes de alimentação de 1.100 W

Modelo	Tensão de entrada	Configuração da fonte de alimentação	Consumo de corrente constante máxima (A)	Potência constante máxima (W)
N3132PX-ON	100 V/60 Hz	Duas de 1.100 W	19,16 A	1.911,2 W
	110 V/60 Hz	Duas de 1.100 W	17,24 A	1.892 W
	120 V/60 Hz	Duas de 1.100 W	15,68 A	1.873 W
	220 V/50 Hz	Duas de 1.100 W	8,37 A	1.819 W
	240 V/50 Hz	Duas de 1.100 W	7,7 A	1.819,2 W

A Tabela 1-9 mostra a alocação de energia do PoE de 1.440 W de uma fonte de alimentação de 1.100 W + uma fonte de 715 W.

Tabela 1-9. Alocação de energia do PoE: 1.440 W de uma fonte de alimentação de 1.100 W + uma fonte de 715 W

Modelo	Tensão de entrada	Configuração da fonte de alimentação	Consumo de corrente constante máxima (A)	Potência constante máxima (W)
N3132PX-ON	100 V/60 Hz	1.100 W/715 W	17,51 A	1.748 W
	110 V/60 Hz	1.100 W/715 W	15,7 A	1.722,3 W
	120 V/60 Hz	1.100 W/715 W	14,36 A	1.704,2 W
	220 V/50 Hz	1.100 W/715 W	7,63 A	1.663,1 W
	240 V/50 Hz	1.100 W/715 W	6,99 A	1.656,3 W

Sistema de ventilação

Dois ventiladores resfriam os comutadores N3132PX-ON em uma única unidade substituível em campo (FRU). Os comutadores N3132PX-ON têm adicionalmente uma ventilador em cada fonte de alimentação interna.

Resumo do modelo N3132PX-ON

Tabela 1-10. Números regulatórios do computador N3132PX-ON

Nome comercial do modelo (MMN)	Descrição	Unidade da fonte de alimentação (PSU)	Número de modelo regulatório (RMN)	Número de tipo regulatório (RTN)
N3132PX-ON	24x1G/8x5G/4x10G SFP+/ 1x compartimento de módulos/1+1 PSUs redundantes conectáveis/ 32 portas PoE 60 W/1x módulo removível de ventilador	1100W/ 715W	E06W	E06W003

Instalação do N3132PX-ON

Montagem de um comutador N3132PX-ON em rack

Coloque o comutador em uma prateleira do rack ou monte o comutador diretamente em um rack de 19 polegadas compatível com a norma EIA-310-E (métodos de quatro colunas, de duas colunas ou com rosca). O sistema Dell ReadyRail é fornecido para instalações em um rack frontal 1U e em duas colunas. O sistema ReadyRail inclui dois conjuntos de trilho embalados separadamente.



ADVERTÊNCIA: Esta é uma referência condensada. Antes de começar, leia as instruções de segurança contidas no folheto de informações de segurança, normalização e meio ambiente.



NOTA: As ilustrações deste documento não representam um comutador específico.

Considerações sobre segurança da montagem em rack

- Carregamento do rack — A sobrecarga ou o carregamento não uniforme de racks pode resultar em uma falha na prateleira ou no rack, causando danos ao equipamento e possivelmente lesões corporais. Estabilize o rack em um local permanente antes de começar a carregá-lo. Monte os componentes começando na parte inferior do rack e depois vá daí para cima. Não exceda a capacidade de carga do rack.
- Considerações sobre energia — Faça a conexão apenas à fonte de energia especificada na unidade. Quando múltiplos componentes elétricos são instalados em um rack, garanta que o valor nominal de potência total do componente não exceda a capacidade do circuito. Fontes de energia e cabos de extensão sobrecarregados apresentam perigo de incêndio e de choque.
- Temperatura ambiente elevada — Se instalado em um rack fechado, a temperatura operacional ambiente do rack pode ser mais alta do que a temperatura ambiente da sala. Cuidado para não exceder a temperatura ambiente máxima do comutador de 45 °C.

- Fluxo de ar reduzido — Instale o equipamento no rack de modo que a quantidade de fluxo de ar necessária para a operação segura do equipamento não seja comprometida.
- Aterramento confiável — Mantenha o aterramento confiável do equipamento montado em rack. Preste atenção especial às conexões de alimentação além das conexões diretas com o circuito de derivação; por exemplo, o uso de filtros de linha.
- O produto não deve ser montado com o painel traseiro voltado para baixo.

Instalar o sistema Dell ReadyRail

O sistema de montagem em rack ReadyRail é fornecido para configurar facilmente o seu rack para a instalação do comutador. O sistema ReadyRail pode ser instalado usando o método 1U sem ferramentas ou um dos três possíveis métodos 1U com ferramentas (montagem nivelada de duas colunas, montagem central de duas colunas ou montagem rosqueada de quatro colunas).

Configuração 1U sem ferramentas (quatro colunas com orifício quadrado ou orifício redondo sem rosca)

- 1 Com as orelhas do flange do ReadyRail voltadas para fora, coloque um trilho entre as colunas verticais esquerda e direita. Alinhe e assente as cavilhas traseiras do trilho do flange no orifício do flange da coluna vertical. Na Figura 1-3, o item 1 e os respectivos detalhes ilustram como as cavilhas se encaixam tanto nos orifícios quadrados quanto nos orifícios redondos sem rosca.

Figura 1-3. Configuração 1U sem ferramentas

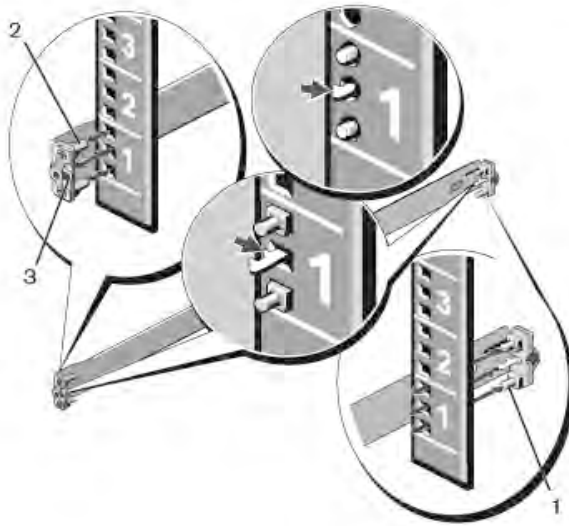

- 2 Alinhe e assente as cavilhas do flange frontal nos orifícios da face frontal da coluna vertical. Veja a Figura 1-3, item 2.
- 3 Repita este procedimento para o segundo trilho.
- 4 Para remover cada trilho, pressione o botão de liberação da trava em cada orelha do flange e desencaixe o trilho. Veja a Figura 1-3, item 3.

Configuração nivelada com duas colunas

- 1 Para esta configuração, as peças fundidas devem ser removidas do lado frontal de cada conjunto do ReadyRail. Veja a Figura 1-4, item 1 na página 129. Use uma chave Torx para remover os dois parafusos de cada orelha de flange frontal (no lado do trilho que fica em contato com o comutador) e remova cada peça fundida. Guarde as peças fundidas para as futuras exigências do rack. Não é necessário remover as peças fundidas traseiras do flange.

Figura 1-4. Configuração nivelada com duas colunas

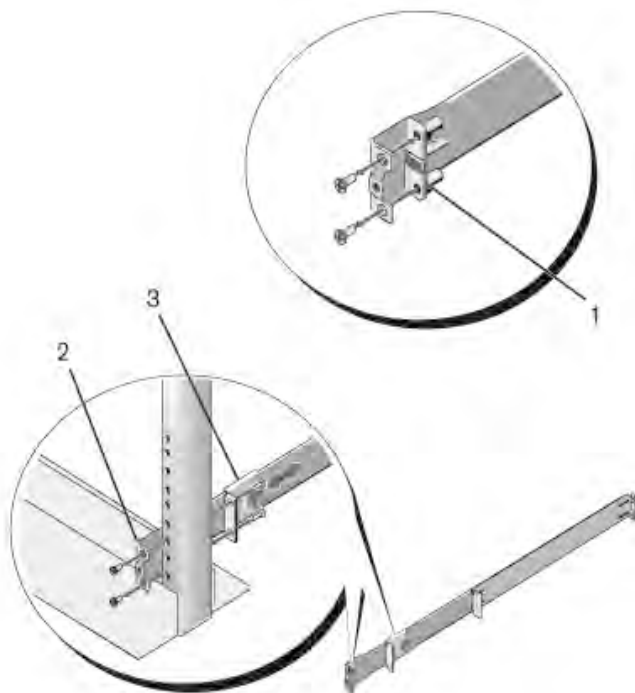

- 2 Conecte um trilho ao flange da coluna frontal com os dois parafusos fornecidos pelo usuário. Veja a Figura 1-4, item 2.
- 3 Empurre o prendedor de pistão contra a coluna vertical e prenda-o ao flange da coluna com dois parafusos fornecidos pelo usuário. Veja a Figura 1-4, item 3.
- 4 Repita este procedimento para o segundo trilho.

Configuração central com duas colunas

- 1 Empurre o prendedor de pistão para trás até que ele se encaixe com um clique e prenda-o ao flange da coluna frontal com dois parafusos fornecidos pelo usuário. Veja a Figura 1-5, item 1.

Figura 1-5. Configuração central com duas colunas

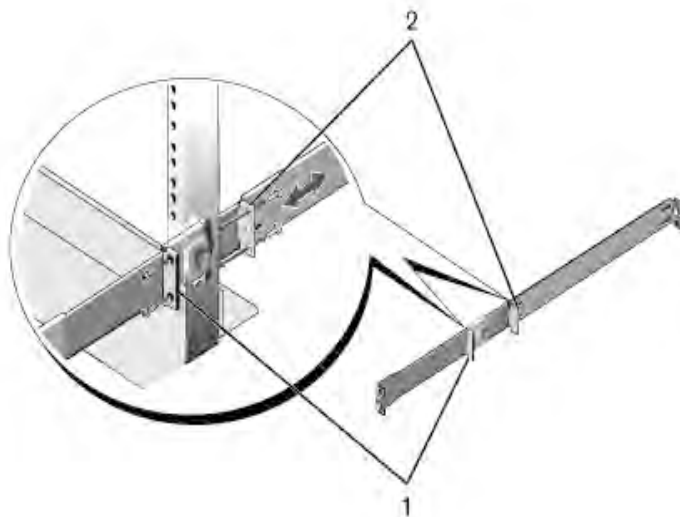

- 2 Deslize o suporte traseiro em direção à coluna e prenda-o ao flange da coluna com os dois parafusos fornecidos pelo usuário. Veja a Figura 1-5, item 2.
- 3 Repita este procedimento para o segundo trilho.

Configuração com rosca em quatro colunas

- 1 Para esta configuração, as peças fundidas da orelha do flange devem ser removidas de cada extremidade dos conjuntos ReadyRail. Use uma chave Torx para remover os dois parafusos de cada orelha do flange e remova cada peça fundida. Veja a Figura 1-6, item 1. Guarde as peças fundidas para as futuras exigências do rack.
- 2 Para cada trilho, conecte os flanges frontal e traseiro aos flanges das colunas com os dois parafusos fornecidos pelo usuário, em cada extremidade. Veja a Figura 1-6, item 2.

Figura 1-6. Configuração com rosca em quatro colunas

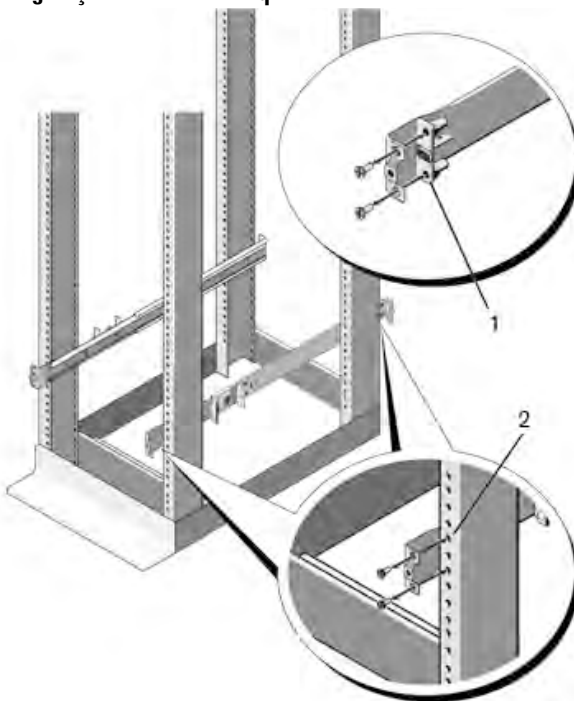

Como instalar um comutador independente



NOTA: A Dell recomenda expressamente a montagem do comutador em um rack.

Instale o comutador sobre uma superfície plana caso não o esteja instalando em um rack. A superfície deve ser capaz de suportar o peso do comutador e de seus respectivos cabos. O comutador é fornecido com quatro bases de borracha auto-adesivas.

- 1 Fixe as bases de borracha auto-adesivas em cada local marcado na parte inferior do comutador.
- 2 Coloque o comutador sobre uma superfície plana e certifique-se de que há uma ventilação adequada deixando um espaço de 5 cm (2 polegadas) em cada lado e de 13 cm (5 polegadas) na parte de trás.

Como empilhar vários comutadores N3132PX-ON

É possível empilhar até 12 comutadores N3132PX-ON com o uso das portas mini-SAS localizadas no módulo de expansão de empilhamento opcional que pode ser inserido na traseira do comutador. Quando vários comutadores são conectados através das portas de empilhamento, eles funcionam como uma única unidade. Consulte o *User Configuration Guide* (Guia de configuração do usuário) e o *CLI Reference Guide* (Guia de referência da interface de linha de comando) para obter mais informações.

Como iniciar e configurar o comutador N3132PX-ON

O fluxograma na Figura 1-7 fornece uma visão geral das etapas usadas para executar a configuração inicial após desembalar e montar o comutador.

Figura 1-7. Fluxograma de instalação e configuração

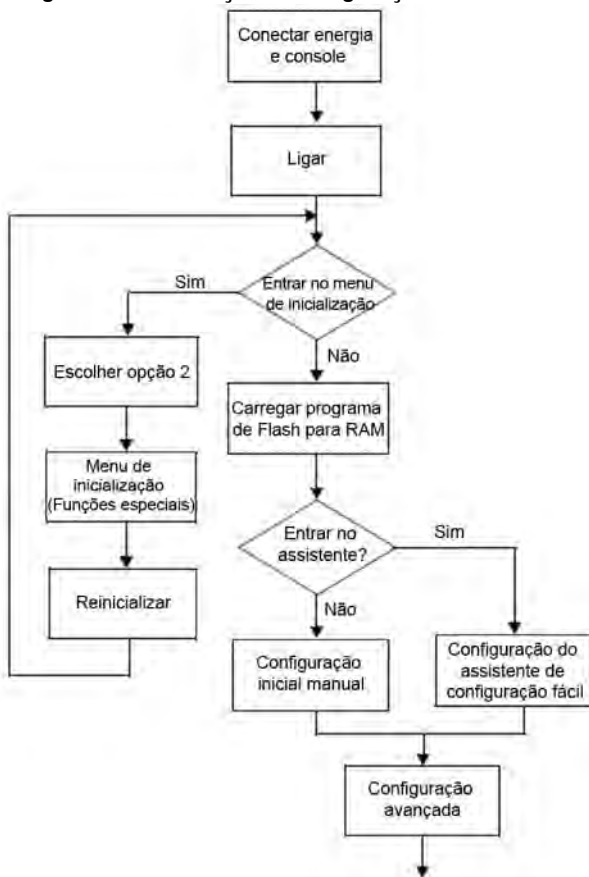

Como conectar um comutador N3132PX-ON a um terminal

Após concluir todas as conexões externas, configure o comutador conectando-o a um terminal.



NOTA: antes de continuar, leia as notas de versão do produto. Você pode fazer o download das notas de versão no site de suporte técnico da Dell em dell.com/support (em inglês).



NOTA: A Dell recomenda que você obtenha a versão mais recente da documentação do usuário do site de suporte técnico da Dell em dell.com/support (em inglês).

Para monitorar e configurar o comutador através do console serial, use a porta de console USB no painel frontal do comutador (consulte Figura 1-8 na página 135) para conectá-lo a um terminal VT100 ou a um computador executando o software de emulação de terminal VT100. A porta de console é implementada como um conector DTE (Data terminal equipment - Equipamento terminal de dados).

Para usar a porta de console, o seguinte equipamento é necessário:

- Terminal compatível com VT100 ou um computador com uma porta serial executando o software de emulação de terminal VT100, como o Microsoft HyperTerminal.
- Um cabo serial (fornecido) com um conector RJ-45 para a porta de console e conector DB-9 para o terminal.

Proceda da seguinte forma para conectar o terminal à porta de console do comutador:

- 1 Conecte o conector DB-9 do cabo serial ao terminal ou ao computador que está rodando o software de emulação de terminal VT100.
- 2 Configure o software de emulação de terminal da seguinte forma:
 - a Selecione a porta serial adequada (por exemplo, COM 1) para ser conectada ao console.
 - b Configure a taxa de dados para 115.200 bauds.
 - c Configure o formato de dados em 8 bits de dados, 1 bit de parada e sem paridade.
 - d Configure o controle de fluxo para nenhum.

Os comutadores N3132PX-ON têm duas fontes de alimentação em unidade substituível em campo (FRU) para operação redundante ou de compartilhamento de carga.

Figura 1-9. Duas fontes de alimentação redundantes no N3132PX-ON



Conexão de alimentação CA e CC

- 1** Certifique-se de que a porte de console do comutador está conectada a um terminal VT100 ou a um emulador de terminal VT100 por meio do cabo fêmea RJ-45 para DB-9.
- 2** Com o uso de um cabo de alimentação padrão de 1,5 m (5 pés) com aterramento de segurança conectado, conecte o cabo de alimentação ao receptáculo principal de CA localizado no painel traseiro.
- 3** Conecte o cabo de alimentação somente a uma tomada elétrica aterrada.

Como inicializar o comutador N3132PX-ON

Quando a energia é ligada com o terminal local já conectado, o comutador inicia um teste automático de ligação (POST). O POST é executado sempre que o comutador é inicializado e verifica os componentes de hardware para determinar se o comutador está plenamente operacional antes de efetuar completamente a inicialização. Se o POST detecta um problema crítico, o fluxo de programa é interrompido. Se o POST é executado com êxito, o firmware válido é carregado dentro da RAM. As mensagens de POST são exibidas no terminal e indicam o êxito ou a falha no teste. O processo de inicialização é executado por aproximadamente 60 segundos.

É possível chamar o menu **Boot** (Inicialização) após a primeira parte do POST estar concluída. A partir do menu **Boot** (Inicialização), é possível executar tarefas de configuração como a redefinição do sistema para os padrões de fábrica, a ativação da imagem de backup ou a recuperação de uma senha. Para obter mais informações sobre as funções do menu **Boot** (Inicialização), consulte o *CLI Reference Guide* (Guia de referência da interface de linha de comando).

Como executar a configuração inicial do N3132PX-ON

O procedimento da configuração inicial está baseado nas seguintes premissas:

- O comutador Dell Networking nunca foi configurado anteriormente.
- O comutador Dell Networking inicializou com êxito.
- A conexão do console foi estabelecida e o prompt do **Dell Easy Setup Wizard** (Assistente de configuração rápida da Dell) aparece na tela de um terminal VT100 ou equivalente.

A configuração inicial do comutador é executada através da porta de console. Após a configuração inicial, é possível gerenciar o comutador da porta de console já conectada ou remotamente através de uma interface definida durante a configuração inicial.



NOTA: O comutador não está configurado com um nome de usuário ou senha padrão. O endereço IP padrão é definido como DHCP para a porta fora da banda (OOB).

Antes de definir a configuração inicial do comutador, obtenha as seguintes informações do administrador de rede:

- O endereço IP a ser atribuído à interface de gerenciamento.
- A máscara de sub-rede IP da rede.
- O endereço IP do gateway padrão da interface de gerenciamento.

Estas configurações são necessárias para permitir o gerenciamento remoto do comutador por Telnet (cliente Telnet) ou HTTP (navegador).

Como habilitar o gerenciamento remoto

O painel frontal do comutador N3132PX-ON contém uma porta Gigabit Ethernet para gerenciamento OOB. A porta OOB está localizada à direita da porta de console. Nos comutadores N3132PX-ON, use a porta OOB ou qualquer uma das portas no painel frontal do comutador para gerenciamento na banda. Por padrão, todas as portas na banda são membros da VLAN 1.

O **Dell Easy Setup Wizard** (Assistente de configuração rápida da Dell) inclui prompts para configurar as informações de rede da interface de gerenciamento OOB no comutador N3132PX-ON e da interface da VLAN 1

nos comutadores N3132PX-ON. Para qualquer interface de gerenciamento é possível atribuir um endereço IP estático e máscara de sub-rede ou habilitar DHCP e permitir que um servidor DHCP da rede atribua as informações.

Consulte o *CLI Reference Guide* (Guia de referência da interface de linha de comando) com relação a comandos para configurar as informações de rede.

Procedimento de configuração inicial

Execute a configuração inicial com o uso do **Dell Easy Setup Wizard** (Assistente de configuração rápida da Dell) ou da CLI. O assistente inicia automaticamente quando o arquivo de configuração do comutador está vazio. É possível sair do assistente a qualquer momento ao pressionar [ctrl+z], mas todas as definições de configuração especificadas serão descartadas e o comutador usará os valores padrão.



NOTA: Se você não executar o **Dell Easy Setup Wizard** (Assistente de configuração rápida da Dell) ou não responder ao prompt inicial do Easy Setup Wizard dentro de 60 segundos, o comutador entra no modo CLI. É preciso redefinir o comutador com uma configuração de inicialização vazia de forma a executar novamente o **Dell Easy Setup Wizard** (Assistente de configuração rápida da Dell).

Para obter mais informações sobre como executar a configuração inicial com o uso da CLI, consulte o *CLI Reference Guide* (Guia de referência da interface de linha de comando). Este *Guia de Noções Básicas* mostra como usar o **Dell Easy Setup Wizard** (Assistente de configuração rápida da Dell) para efetuar a configuração inicial do comutador. O assistente define a seguinte configuração no comutador:

- Estabelece a conta de usuário com privilégios inicial com uma senha válida. O assistente configura uma única conta de usuário com privilégios durante a configuração.
- Habilita login da CLI e acesso HTTP para usar somente a configuração de autenticação local.
- Define o endereço IP da interface de gerenciamento OOB.
- Define o endereço IP da interface de roteamento da VLAN 1, da qual todas as portas na banda são membros.
- Define a string de comunidade SNMP a ser usada pelo gerente de SNMP em um dado endereço IP. Ignore esta etapa se o gerenciamento de SNMP não for usado para o comutador em questão.

- Permite especificar o endereço IP do sistema de gerenciamento da rede ou autoriza o acesso de gerenciamento a partir de todos os endereços IP.
- Configura o endereço IP do gateway padrão para a interface da VLAN 1.

Sessão de exemplo

Esta seção descreve uma sessão do **Dell Easy Setup Wizard** (Assistente de configuração rápida da Dell). Os valores a seguir serão usados pela sessão de exemplo:

- A cadeia de caracteres da comunidade SNMP a ser usada é **public**.
- O endereço IP do sistema de gerenciamento de rede (NMS) é **10.1.2.100**.
- O nome de usuário é **admin** e a senha é **admin123**.
- A interface de gerenciamento OOB usa **DHCP** para atribuição de endereço IP.
- O endereço IP para a interface de roteamento da VLAN 1 é **10.1.1.200** com uma máscara de sub-rede igual a **255.255.255.0**.
- O gateway padrão é **10.1.1.1**.

O assistente de configuração atribui os valores iniciais como definido acima. Após concluir o assistente, o comutador está configurado como a seguir:

- SNMPv2 está habilitado e a cadeia de caracteres da comunidade está configurada como definido acima. SNMPv3 está habilitado por padrão.
- A conta de usuário admin está configurada como definido acima.
- Um sistema de gerenciamento de rede está configurado. A partir da estação de gerenciamento, é possível acessar as interfaces de SNMP, HTTP e CLI.
- DHCP está habilitado na interface de gerenciamento OOB.
- Um endereço IP está configurado para a interface de roteamento da VLAN 1.
- O endereço do gateway padrão está configurado.



NOTA: no exemplo a seguir, as possíveis opções do usuário ou valores padrão estão entre []. Caso você pressione <Enter> sem qualquer opção definida, o valor padrão será aceito. O texto de ajuda se encontra entre parênteses.

Exemplo do console do Dell Easy Setup Wizard

O exemplo a seguir contém a sequência de prompts e as respostas associadas à execução de uma sessão de exemplo do **Dell Easy Setup Wizard** (Assistente de configuração rápida da Dell), usando os valores de entrada listados anteriormente.

Após o computador concluir o POST e ter inicializado, o seguinte diálogo é exibido:

```
Unit 1 - Waiting to select management unit)>
```

```
_____Dell SupportAssist EULA_____
```

```
I accept the terms of the license agreement. You can  
reject the license agreement by configuring this  
command 'eula-consent support-assist reject'.
```

```
By installing SupportAssist, you allow Dell to save  
your contact information (e.g. name, phone number  
and/or email address) which would be used to provide  
technical support for your Dell products and services  
Dell may use the information for providing  
recommendations to improve your IT infrastructure.  
Dell SupportAssist also collects and stores machine  
diagnostic information, which may include but is not  
limited to configuration information, user supplied  
contact information, names of data volumes, IP  
addresses, access control lists, diagnostics &  
performance information, network configuration  
information, host/server configuration & performance  
information and related data (Collected Data) and  
transmits this information to Dell. By downloading  
SupportAssist and agreeing to be bound by these terms  
and the Dell end user license agreement, available at:  
http://www.dell.com/aeula, you agree to allow Dell to  
provide remote monitoring services of your IT  
environment and you give Dell the right to collect the  
Collected Data in accordance with Dell's Privacy  
Policy, available at:  
http://www.dell.com/privacypolicycountryspecific, in  
order to enable the performance of all of the various
```

functions of SupportAssist during your entitlement to receive related repair services from Dell. You further agree to allow Dell to transmit and store the Collected Data from SupportAssist in accordance with these terms. You agree that the provision of SupportAssist may involve international transfers of data from you to Dell and/or to Dell's affiliates, subcontractors or business partners. When making such transfers, Dell shall ensure appropriate protection is in place to safeguard the Collected Data being transferred in connection with SupportAssist. If you are downloading SupportAssist on behalf of a company or other legal entity, you are further certifying to Dell that you have appropriate authority to provide this consent on behalf of that entity. If you do not consent to the collection, transmission and/or use of the Collected Data, you may not download, install or otherwise use SupportAssist.

_____AeroHive HiveManager NG EULA_____

This switch includes a feature that enables it to work with HiveManager (an optional management suite), by sending the switch's service tag number and IP Address to HiveManager to authenticate your entitlement to use HiveManager. If you wish to disable this feature, you should run command 'eula-consent hiveagent reject' immediately upon powering up the switch for the first time, or at any time thereafter.

Applying Global configuration, please wait...

Welcome to Dell Easy Setup Wizard

The setup wizard guides you through the initial switch configuration, and gets you up and running as quickly as possible. You can skip the setup wizard, and enter CLI mode to manually configure the switch. You must respond to the next question to run the setup wizard within 60 seconds, otherwise the system will continue

with normal operation using the default system configuration. Note: You can exit the setup wizard at any point by entering [ctrl+z].

Would you like to run the setup wizard (you must answer this question within 60 seconds)? [Y/N] **y**

Step 1:

The system is not set up for SNMP management by default. To manage the switch using SNMP (required for Dell Network Manager) you can

- . Set up the initial SNMP version 2 account now.
- . Return later and set up other SNMP accounts. (For more information on setting up an SNMP version 1 or 3 account, see the user documentation).

Would you like to set up the SNMP management interface now? [Y/N] **y**

To set up the SNMP management account you must specify the management system IP address and the "community string" or password that the particular management system uses to access the switch. The wizard automatically assigns the highest access level [Privilege Level 15] to this account. You can use Dell Network Manager or other management interfaces to change this setting, and to add additional management system information later. For more information on adding management systems, see the user documentation.

To add a management station:

Please enter the SNMP community string to be used.

[public]: **public**



NOTA: caso esteja configurado, o nível de acesso padrão é definido com o máximo nível de acesso disponível para a interface de gerenciamento SNMP. Inicialmente, somente SNMPv2 será ativado. SNMPv3 estará desabilitado até que você retorne a configurar o acesso de segurança de SNMPv3 (por exemplo: engine ID, view, etc.).

Please enter the IP address of the Management System (A.B.C.D) or wildcard (0.0.0.0) to manage from any Management Station. [0.0.0.0]: **10.1.2.100**

Step 2:

Now we need to set up your initial privilege (Level 15) user account. This account is used to login to the CLI and Web interface. You may set up other accounts and change privilege levels later. For more information on setting up user accounts and changing privilege levels, see the user documentation.

To set up a user account:

```
Please enter the user name. [root]:admin
Please enter the user password: *****
Please reenter the user password: *****
```

Step 3:

Next, IP addresses are set up on the OOB (Out-Of-Band) Interface and/or the VLAN 1 routing interface.

You can use these IP addresses to access the CLI, Web interface, or SNMP interface of the switch.

To access the switch through any Management Interface you can

- . Set up the IP address for the Management Interface.
- . Set up the default gateway if IP address is manually configured on both routing and OOB interface.

```
Would you like to set up the Out-Of-Band interface now? [Y/N] y
```

```
Please enter the IP address of the device (A.B.C.D) or enter "DHCP" (without the quotes) to automatically request an IP address from the network DHCP server.
[DHCP]: dhcp
```

Step 4:

```
Would you like to set up the VLAN1 routing interface now? [Y/N] y
```

Please enter the IP address of the device (A.B.C.D) or enter "DHCP" (without the quotes) to automatically request an IP address from the network DHCP server:

10.1.1.200

Please enter the IP subnet mask (A.B.C.D or /nn):

255.255.255.0

Step 5:

Finally, set up the default gateway. Please enter the IP address of the gateway from which this network is reachable. [0.0.0.0]: **10.1.1.1**

This is the configuration information that has been collected:

SNMP Interface = "public"@10.1.2.100

User Account setup = admin

Password = *****

Out-of-band IP address = DHCP

VLAN1 Router Interface IP = 10.1.1.200 255.255.255.0

Default Gateway = 10.1.1.1

Step 6:

If the information is correct, please enter (Y) to save the configuration and copy the settings to the start-up configuration file. If the information is incorrect, enter (N) to discard the configuration and restart the wizard: [Y/N] **y**

Thank you for using the Dell Easy Setup Wizard. You will now enter CLI mode.

Applying Interface configuration, please wait...

Próximas etapas

Após concluir a configuração inicial descrita nesta seção, conecte a porta OOB à sua rede de gerenciamento para gerenciamento remoto OOB, ou conecte qualquer uma das portas do painel frontal do comutador a uma rede de produção para gerenciamento remoto na banda.

Caso tenha especificado DHCP para o endereço IP da interface de gerenciamento OOB ou da VLAN 1, a interface obterá seu endereço IP de um servidor DHCP na rede. Para descobrir o endereço IP atribuído dinamicamente, use a conexão da porta de console para emitir os seguintes comandos:

- Na interface OOB, digite **show ip interface out-of-band**.
- Na interface de roteamento da VLAN 1, digite **show ip interface vlan 1**.

Para ter acesso à interface do Dell OpenManage Switch Administrator, digite o endereço IP da interface de gerenciamento OOB no campo de endereço de um navegador da Web. Para acesso de gerenciamento remoto para a CLI, digite o endereço IP da interface de gerenciamento da VLAN 1 em um cliente Telnet ou SSH. Como alternativa, é possível continuar a usar a porta de console para acesso de CLI local ao comutador.

O comutador N3132PX-ON suporta recursos de chaveamento básico como VLANs e protocolo de estrutura estendida. Os comutadores N3132PX-ON também suportam recursos avançados da Camada 3 como roteamento dinâmico e multicast (difusão seletiva). Use a interface de gerenciamento baseada na Web ou a CLI para configurar os recursos demandados por sua rede. Para obter informações sobre como configurar os recursos do comutador, consulte o *User Configuration Guide* (Guia de configuração do usuário) ou o *CLI Reference Guide* (Guia de referência da interface de linha de comando), disponíveis no site de suporte: dell.com/support (em inglês).

Informações da norma NOM (apenas para o México)

As informações a seguir são fornecidas no(s) produto(s) descrito(s) neste documento de acordo com os requisitos das Normas Oficiais Mexicanas (NOM):

Exportador:	Dell Inc. One Dell Way Round Rock, TX 78682
Importador:	Dell Computer de México, S.A. de C.V. Paseo de la Reforma 2620 - 11º Piso Col. Lomas Altas 11950 México, D.F.
Enviar para:	Dell Computer de México, S.A. de C.V. al Cuidado de Kuehne & Nagel de México S. de R.L. Avenida Soles No. 55 Col. Peñon de los Baños 15520 México, D.F.
Tensão de alimentação:	Dell Networking N2128PX-ON/N3132PX-ON : 100 V-240 V CA
Frequência:	Dell Networking N2128PX-ON/N3132PX-ON : 50 a 60 Hz
Consumo de corrente constante máxima:	N2128PX-ON: <ul style="list-style-type: none">• Circuito de 110 V: 0,80 A• Circuito de 220 V: 0,43 A N3132PX-ON: <ul style="list-style-type: none">• Circuito de 110 V: 0,80 A• Circuito de 220 V: 0,40 A
NOTA: a corrente mostrada aqui é de consumo de uma única fonte de alimentação.	

Dell Networking
Conmutadores N2128PX-ON/
N3132PX-ON

Guía de introducción

Modelos normativos: N2128PX-ON/
N3132PX-ON



Notas, precauciones y avisos



NOTA: Una NOTA proporciona información importante que le ayudará a utilizar mejor el equipo.



PRECAUCIÓN: Un mensaje de PRECAUCIÓN indica la posibilidad de daños en el hardware o la pérdida de datos, e informa de cómo evitar el problema.



AVISO: Un mensaje de AVISO indica el riesgo de daños materiales, lesiones o incluso la muerte.

Copyright © 2016 Dell Inc. Todos los derechos reservados. Este producto está protegido por las leyes de EE. UU. y las leyes internacionales sobre el derecho de copia y la propiedad intelectual.

Dell™ y el logotipo de Dell son marcas comerciales de Dell Inc. en Estados Unidos y otras jurisdicciones. Todas las demás marcas y nombres mencionados aquí pueden ser marcas comerciales de sus respectivas compañías.

Modelos normativos de N2128PX-ON/N3132PX-ON

Contenido

1	Introducción	155
	Descripción general del hardware N2128PX-ON	155
	Consumo de energía de los conmutadores N2128PX-ON PoE	155
	Resumen de modelos N2128PX-ON	157
2	Instalación de N2128PX-ON	158
	Montaje del conmutador N2128PX-ON en bastidor.	158
	Instalación en bastidor	158
	Instalación independiente del conmutador	159
	Apilamiento de varios conmutadores N2128PX-ON	160
3	Inicio y configuración del conmutador N2128PX-ON	161
	Conexión de un conmutador N2128PX-ON a un terminal	162
	Conexión de un conmutador N2128PX-ON a una fuente de alimentación	163
	Conexiones de alimentación de CA y de CC	163
	Inicio del conmutador N2128PX-ON.	164

	Cómo realizar la configuración inicial de N2128PX-ON	165
	Activación de la administración remota	165
	Procedimiento para la configuración inicial	166
	Sesión de ejemplo	167
	Ejemplo de la consola de Dell Easy Setup Wizard	168
	Pasos siguientes	172
4	Descripción general del hardware N3132PX-ON	174
	Consumo de energía de los conmutadores N3132PX-ON PoE	174
	Sistema de ventilación	176
	Resumen de modelos N3132PX-ON	177
5	Instalación de N3132PX-ON	178
	Montaje del conmutador N3132PX-ON en bastidor	178
	Consideraciones sobre la seguridad del montaje del bastidor	178
	Instalación de Dell ReadyRail System	179
	Instalación independiente del conmutador	184
	Apilamiento de varios conmutadores N3132PX-ON	184
6	Inicio y configuración del conmutador N3132PX-ON	185
	Conexión de un conmutador N3132PX-ON a un terminal	186

Conexión de un conmutador N3132PX-ON a una fuente de alimentación	187
Conexiones de alimentación de CA y de CC	188
Inicio del conmutador N3132PX-ON.	188
Cómo realizar la configuración inicial de N3132PX-ON	189
Activación de la administración remota	189
Procedimiento para la configuración inicial	190
Sesión de ejemplo	192
Ejemplo de la consola de Dell Easy Setup Wizard	193
Pasos siguientes	197
7 Información de la NOM (sólo para México)	199

Introducción

Este documento proporciona información básica acerca de los conmutadores Dell® Networking N2128PX-ON/N3132PX-ON, incluyendo cómo instalarlos y cómo realizar la configuración inicial. Para obtener información acerca de cómo configurar y supervisar las características del conmutador, consulte la *Guía de configuración del usuario*, disponible en la página web de soporte de Dell en dell.com/support, que también ofrece las actualizaciones más recientes de documentación y firmware.



NOTA: Se recomienda encarecidamente a los administradores de conmutadores que mantengan los conmutadores Dell Networking en la versión más reciente de Dell Networking Operating System (DNOS). Dell Networking mejora de forma continua las características y las funciones de DNOS en función de los comentarios que recibe de los clientes. Para las infraestructuras críticas, se recomienda realizar una preconfiguración de la nueva versión en una parte de la red que no sea crítica, con el objetivo de verificar el funcionamiento y la configuración de la red con la nueva versión de DNOS.

Descripción general del hardware N2128PX-ON

Esta sección contiene información acerca de las características del dispositivo y las configuraciones de hardware modular para el conmutador Dell Networking N2128PX-ON.

Consumo de energía de los conmutadores N2128PX-ON PoE

La Tabla 1-1 describe el consumo de energía de los conmutadores N2128PX-ON PoE. El consumo de energía del sistema es de 90 vatios (W). La asignación de energía PoE es de 800 W para la fuente de alimentación (PSU) principal.

Tabla 1-1. Consumo de energía de los conmutadores N2128PX-ON PoE

Modelo	Tensión de entrada	Configuración de la fuente de alimentación	Consumo máximo de corriente constante (A)	Alimentación constante máxima (W)
N2128PX-ON	100 V/60 Hz	PSU principal	9,73 A	965,5 W
	110 V/60 Hz	PSU principal	8,75 A	960,4 W
	120 V/60 Hz	PSU principal	8,03 A	958,3 W
	220 V/50 Hz	PSU principal	4,33 A	931 W
	240 V/50 Hz	PSU principal	3,97 A	928,7 W

La Tabla 1-2 muestra la información de consumo de energía de los conmutadores N2128PX-ON habilitados con PoE que se ejecutan únicamente desde la fuente de alimentación modular (MPS).

La asignación de energía PoE es de 800 W para la MPS.

Tabla 1-2. Información de consumo de energía de los conmutadores N2128PX-ON PoE (+ MPS)

Modelo	Tensión de entrada	Configuración de la fuente de alimentación	Consumo máximo de corriente constante (A)	Alimentación constante máxima (W)
N2128PX-ON	100 V/60 Hz	MPS	9,92 A	986,5 W
	110 V/60 Hz	MPS	8,93 A	975,7 W
	120 V/60 Hz	MPS	8,01 A	955,4 W
	220 V/50 Hz	MPS	4,44 A	945,4 W
	240 V/50 Hz	MPS	4,08 A	951,4 W

La Tabla 1-3 muestra la información de consumo de energía de los conmutadores N2128PX-ON habilitados con PoE. La asignación de energía PoE es de 1600 W para la fuente de alimentación principal + la fuente de alimentación modular (MPS).

Tabla 1-3. Consumo de energía de los conmutadores N2128PX-ON PoE

Modelo	Tensión de entrada	Configuración de la fuente de alimentación	Consumo máximo de corriente constante (A)	Alimentación constante máxima (W)
N2128PX-ON	100 V/60 Hz	PSU principal + MPS	11,83 A	1175 W
	110 V/60 Hz	PSU principal + MPS	10,71 A	1169 W
	120 V/60 Hz	PSU principal + MPS	9,84 A	1168,9 W
	220 V/50 Hz	PSU principal + MPS	5,4 A	1138,4 W
	240 V/50 Hz	PSU principal + MPS	5,93 A	1141 W

Resumen de modelos N2128PX-ON

Tabla 1-4. Números normativos de los conmutadores N2128PX-ON

Nombre de modelo de comercialización (MMN)	Descripción	Unidad de fuente de alimentación (PSU)	Número de modelo normativo (RMN)	Número de tipo normativo (RTN)
N2128PX-ON	24 x 1 G/4 x 2,5 G/ 2 x 10 G SFP+/ 2x apilamiento/ 24 puertos PoE+/ 4 puertos PoE 60 W	1000 W	E05W	E05W003

Instalación de N2128PX-ON

Montaje del conmutador N2128PX-ON en bastidor

 **AVISO:** Lea la información de seguridad incluida en el manual de *Información de seguridad y normativa*, así como la información de seguridad de cualquier otro conmutador que se conecte al conmutador o sea compatible con el mismo.

El conector de alimentación de CA se encuentra en el panel posterior del conmutador.

Instalación en bastidor

 **AVISO:** No utilice kits de montaje en bastidor para colocar el conmutador en suspensión bajo una mesa o escritorio, ni para acoplarlo a una pared.

 **PRECAUCIÓN:** Desconecte todos los cables del conmutador antes de continuar. Elimine todas las almohadillas autoadhesivas de la parte inferior del conmutador, si se adhirieron previamente.

 **PRECAUCIÓN:** Cuando se instalen varios conmutadores en un bastidor, monte los conmutadores desde la parte inferior hacia arriba.

- 1 Coloque el soporte de montaje en bastidor proporcionado a un lado del conmutador y asegúrese de que los orificios de montaje del conmutador quedan alineados con los orificios de montaje del soporte de montaje en bastidor. La Ilustración 1-1 muestra dónde instalar los soportes.

Ilustración 1-1. Fijación de los soportes



- 2 Inserte los pernos proporcionados en los orificios de montaje en bastidor y apriételos con un destornillador.
- 3 Repita el proceso para el soporte de montaje en bastidor del otro lado del conmutador.
- 4 Inserte el conmutador en el bastidor de 48,26 cm (19 pulg.) y asegúrese de que los orificios de montaje en bastidor del conmutador quedan alineados con los orificios de montaje del bastidor.
- 5 Fije el conmutador al bastidor con los pernos del bastidor o las tuercas enjauladas con sus pernos y arandelas (en función del tipo de bastidor del que disponga). Apriete los pernos de la parte inferior antes de apretar los pernos de la parte superior.

⚠ PRECAUCIÓN: Asegúrese de que los pernos del bastidor proporcionados encajan en los orificios roscados del bastidor.

🔧 NOTA: Asegúrese de que los orificios de ventilación no están bloqueados.

Instalación independiente del conmutador

🔧 NOTA: Dell recomienda encarecidamente montar el conmutador en un bastidor.

Si no es posible montar el conmutador en un bastidor, instálelo en una superficie plana. Dicha superficie debe ser capaz de sostener el peso del conmutador y de los cables del conmutador. El conmutador se envía con cuatro almohadillas de goma autoadhesivas.

- 1 Fije las almohadillas de goma autoadhesivas en las ubicaciones marcadas en la parte inferior del conmutador.

- 2 Coloque el conmutador en una superficie plana y asegúrese de que cuenta con una ventilación adecuada. Para ello, deje 5 cm (2 pulg.) de espacio libre a cada lado y 13 cm (5 pulg.) en la parte posterior.

Apilamiento de varios conmutadores N2128PX-ON

Es posible apilar varios conmutadores N2128PX-ON, hasta una altura de 12 conmutadores, mediante el uso de los puertos mini-SAS ubicados en la parte posterior del conmutador. Cuando se interconectan varios conmutadores a través de los puertos de pila, funcionan como una unidad única con hasta 336 puertos en el panel frontal. La pila se opera y se administra como una única entidad. Para obtener más información, consulte la *Guía de configuración del usuario* y la *Guía de referencia de la línea de comandos*.

Inicio y configuración del conmutador N2128PX-ON

El siguiente diagrama de flujo proporciona una descripción general de los pasos que debe seguir para realizar la configuración inicial del conmutador, una vez que este se ha desembalado y montado.

Ilustración 1-2. Diagrama de flujo de instalación y configuración

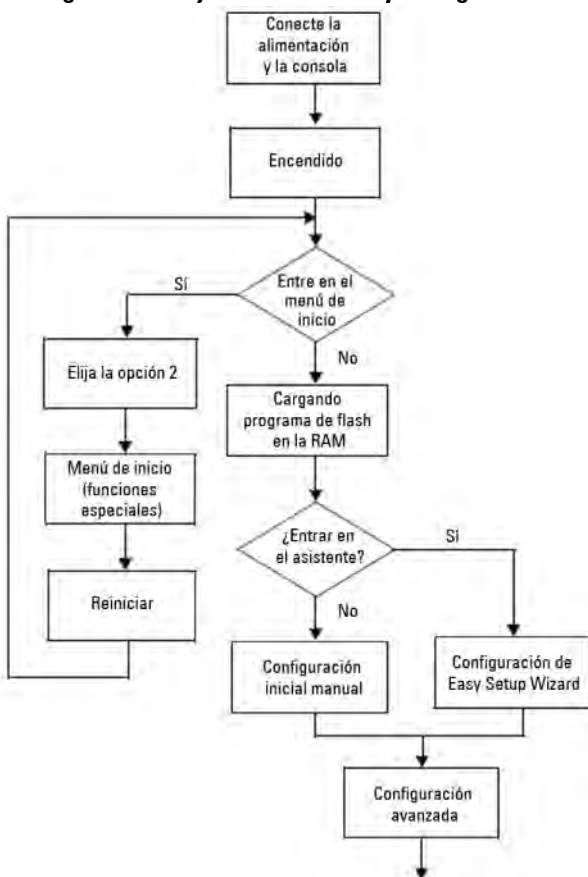

Conexión de un conmutador N2128PX-ON a un terminal

Tras realizar todas las conexiones externas, configure el conmutador. Para ello, conéctelo a un terminal.



NOTA: Lea las notas de la versión de este producto antes de continuar. Puede descargar las notas de la versión de la página web de soporte de Dell en dell.com/support.



NOTA: Dell recomienda obtener la versión más reciente de la documentación del usuario de la página web de soporte de Dell en dell.com/support.

Para supervisar y configurar el conmutador mediante la consola serie, utilice el puerto de consola del panel frontal del conmutador para conectarlo a un terminal VT100 o a un equipo que ejecute el software de emulación de terminal VT100. El puerto de consola se implementa como un conector DTE (Data Terminal Equipment).

El siguiente equipo es necesario para utilizar el puerto de consola:

- Terminal compatible con VT100 o un equipo con un puerto serie que ejecute el software de emulación de terminal VT100, como por ejemplo Microsoft HyperTerminal®.
- Un cable serie (proporcionado) con un conector RJ-45 para el puerto de consola y un conector DB-9 para el terminal.

Realice las siguientes tareas para conectar un terminal al puerto de consola del conmutador:

- 1 Conecte el conector DB-9 del cable serie al terminal o equipo que ejecute el software de emulación de terminal VT100.
- 2 Configure el software de emulación de terminal de la siguiente manera:
 - a Seleccione el puerto serie correspondiente (por ejemplo, COM 1) para conectar a la consola.
 - b Establezca la velocidad de los datos a 115,200 baudios.
 - c Establezca el formato de los datos en 8 bits, 1 bit de detención y sin paridad.
 - d Establezca el control de flujo en ninguno.
 - e Establezca el modo de emulación de terminal en VT100.

- f Seleccione las Teclas de terminal para Función, Flecha y teclas Ctrl. Asegúrese de que el valor establecido es para las teclas del terminal (no para las teclas de Microsoft Windows).
- 3 Conecte el conector RJ-45 del cable directamente al puerto de consola del conmutador. El puerto de consola Dell Networking se encuentra en la parte derecha del panel frontal y está marcado con el símbolo |O|O|.



NOTA: El acceso de la consola serie al administrador de pilas está disponible desde cualquier puerto serie mediante la CLI local. Solo se permite una sesión de consola serie a la vez.

Conexión de un conmutador N2128PX-ON a una fuente de alimentación



PRECAUCIÓN: Lea la información de seguridad incluida en el manual de *Información de seguridad y normativa*, así como la información de seguridad de cualquier otro conmutador que se conecte al conmutador o sea compatible con el mismo.

El modelo N2128PX-ON cuenta con una fuente de alimentación interna. El conector de alimentación se encuentra en el panel posterior.

Conexiones de alimentación de CA y de CC

- 1 Asegúrese de que el puerto de consola del conmutador está conectado a un terminal VT100 o a un emulador de terminal VT100 a través del cable RJ-45 al cable DB-9 hembra.
- 2 Mediante el uso de un cable de alimentación estándar de 1,5 m (5 ft) con la toma a tierra de seguridad conectada, conecte el cable de alimentación al conector principal de CA, que se encuentra en el panel posterior.
- 3 Conecte el cable de alimentación a un enchufe de CA con toma a tierra.
- 4 Si se utiliza una fuente de alimentación de CC externa o redundante, como Dell Networking RPS720 o Dell Networking MPS1000 (solo para N2128PX-ON), conecte el cable de alimentación de CC al conector de alimentación de CC que se encuentra en el panel posterior.

Inicio del conmutador N2128PX-ON

Cuando la alimentación esté activada y el terminal local ya se haya conectado, el conmutador realizará una autopruueba de encendido (POST). La POST se ejecuta cada vez que se inicializa el conmutador y analiza los componentes de hardware para determinar si el conmutador está totalmente operativo antes de iniciarlo por completo. Si la POST detecta un problema crítico, el flujo de programa se detiene. Si la POST se ejecuta correctamente, el firmware válido se carga en la RAM. Los mensajes de la POST se muestran en el terminal e indican que la prueba se ha realizado correcta o incorrectamente. El proceso de inicio se ejecuta durante 60 segundos aproximadamente.

Una vez que se haya completado la primera parte de la POST, puede invocar el menú **Inicio**. Desde el menú **Inicio**, puede realizar tareas de configuración, como el restablecimiento del sistema a los valores predeterminados de fábrica, la activación de la imagen de copia de seguridad o la recuperación de una contraseña. Para obtener más información acerca de las funciones del menú **Inicio**, consulte la *Guía de referencia de línea de comandos*.

Cómo realizar la configuración inicial de N2128PX-ON

El procedimiento de configuración inicial toma por supuesto lo siguiente:

- El conmutador Dell Networking no se ha configurado anteriormente.
- El conmutador Dell Networking se ha iniciado correctamente.
- Se ha establecido conexión con la consola y la petición de **Dell Easy Setup Wizard** aparece en la pantalla de un terminal VT100 o de un terminal equivalente.

La configuración inicial del conmutador se realiza a través del puerto de consola. Tras la configuración inicial, puede administrar el conmutador desde el puerto de consola ya conectado o de forma remota a través de una interfaz definida durante la configuración inicial.



NOTA: El conmutador no se configura con un nombre de usuario predeterminado, una contraseña ni una dirección IP.

Antes de realizar la configuración inicial del conmutador, obtenga la siguiente información de su administrador de red:

- La dirección IP que se asignará a la interfaz de administración.
- La máscara de subred IP para la red.
- La dirección IP de la puerta de enlace predeterminada de la interfaz de administración.

Estos valores son necesarios para permitir la administración remota del conmutador a través de Telnet (cliente Telnet) o HTTP (explorador web).

Activación de la administración remota

Los conmutadores N2128PX-ON/N3132PX-ON permiten el uso de cualquier puerto del panel frontal del conmutador para la administración en banda. De forma predeterminada, todos los puertos en banda son miembros de VLAN 1.

El **Dell Easy Setup Wizard** incluye peticiones para configurar la información de red para la interfaz VLAN 1 en el conmutador N2128PX-ON. Puede asignar una dirección IP estática y una máscara de subred, o habilitar DHCP y permitir que un servidor DHCP de la red asigne esta información.

Para obtener información acerca de los comandos para configurar la información de red, consulte la *Guía de referencia de la línea de comandos*.

Procedimiento para la configuración inicial

Lleve a cabo la configuración inicial mediante el uso de **Dell Easy Setup Wizard** o de la CLI. El asistente se inicia automáticamente cuando el archivo de configuración del conmutador está vacío. Puede abandonar el asistente en cualquier momento pulsando las teclas [Ctrl + z], pero esto hará que se descarten todos los valores de configuración especificados y que el conmutador utilice los ajustes predeterminados.



NOTA: Si no ejecuta **Dell Easy Setup Wizard** o no responde a la petición inicial de Easy Setup Wizard en 60 segundos, el conmutador entrará en el modo CLI. Para volver a ejecutar **Dell Easy Setup Wizard**, deberá restablecer el conmutador con una configuración de inicio vacía.

Para obtener más información acerca de la configuración inicial mediante el uso de la CLI, consulte la *Guía de referencia de la línea de comandos*. Esta *Guía de introducción* describe cómo utilizar **Dell Easy Setup Wizard** para la configuración inicial del conmutador. El asistente establece la siguiente configuración en el conmutador:

- Establece la cuenta de usuario privilegiada inicial con una contraseña válida. El asistente configura una cuenta de usuario privilegiada durante la configuración.
- Permite el inicio de sesión CLI y el acceso HTTP para utilizar únicamente el ajuste de autenticación local.
- Configura la dirección IP para la interfaz de enrutamiento VLAN 1, de la que todos los puertos en banda son miembros.
- Establece la cadena de comunidad SNMP que se va a utilizar por el administrador SNMP a una dirección IP determinada. Puede optar por omitir este paso si la administración SNMP no se utiliza para este conmutador.
- Permite especificar la dirección IP del sistema de administración de red o permite el acceso de administración desde todas las direcciones IP.
- Configura la dirección IP de la puerta de enlace predeterminada para la interfaz VLAN 1.

Sesión de ejemplo

Esta sección describe una sesión de **Dell Easy Setup Wizard**. Los siguientes valores se utilizan en la sesión de ejemplo:

- La cadena de comunidad SNMP que va a utilizar es **pública**.
- La dirección IP del sistema de administración de red (NMS) es **10.1.2.100**.
- El nombre de usuario es **admin** y la contraseña es **admin123**.
- La dirección IP para la interfaz de enrutamiento VLAN 1 es **10.1.1.200** y la máscara de subred es **255.255.255.0**.
- La puerta de enlace predeterminada es **10.1.1.1**.

El asistente para la instalación configura los valores iniciales como se indica anteriormente. Una vez que el asistente finalice, el conmutador estará configurado de la siguiente forma:

- SNMPv2 se habilita y la cadena de comunidad se configura como se indica anteriormente. SNMPv3 se deshabilita de forma predeterminada.
- La cuenta del usuario administrador se configura como se indica anteriormente.
- Se configura un sistema de administración de red. Puede acceder a las interfaces SNMP, HTTP y CLI desde la estación de administración. También puede optar por permitir que todas las direcciones IP tengan acceso a estas interfaces de administración. Para ello, seleccione la dirección IP (0.0.0.0).
- Se configura una dirección IP para la interfaz de enrutamiento VLAN 1.
- Se configura una dirección de puerta de enlace predeterminada.



NOTA: En el siguiente ejemplo, las posibles opciones de usuario o los valores predeterminados se encuentran entre corchetes []. Si pulsa <Intro> sin haber definido una opción, se aplica el valor predeterminado. El texto de ayuda se encuentra entre paréntesis.

Ejemplo de la consola de Dell Easy Setup Wizard

El siguiente ejemplo contiene la secuencia de peticiones y respuestas asociadas a la ejecución de una sesión de ejemplo de **Dell Easy Setup Wizard** mediante el uso de los valores de entrada indicados anteriormente.

Una vez que el conmutador complete la POST y se inicie, aparecerá el siguiente diálogo:

```
Unit 1 - Waiting to select management unit)>
```

```
_____Dell SupportAssist EULA_____
```

```
I accept the terms of the license agreement. You can
reject the license agreement by configuring this
command 'eula-consent support-assist reject'.
```

```
By installing SupportAssist, you allow Dell to save
your contact information (e.g. name, phone number
and/or email address) which would be used to provide
technical support for your Dell products and services
Dell may use the information for providing
recommendations to improve your IT infrastructure.
Dell SupportAssist also collects and stores machine
diagnostic information, which may include but is not
limited to configuration information, user supplied
contact information, names of data volumes, IP
addresses, access control lists, diagnostics &
performance information, network configuration
information, host/server configuration & performance
information and related data (Collected Data) and
transmits this information to Dell. By downloading
SupportAssist and agreeing to be bound by these terms
and the Dell end user license agreement, available at:
http://www.dell.com/aeula, you agree to allow Dell to
provide remote monitoring services of your IT
environment and you give Dell the right to collect the
Collected Data in accordance with Dell's Privacy
Policy, available at:
http://www.dell.com/privacypolicycountryspecific, in
order to enable the performance of all of the various
functions of SupportAssist during your entitlement to
```

receive related repair services from Dell. You further agree to allow Dell to transmit and store the Collected Data from SupportAssist in accordance with these terms. You agree that the provision of SupportAssist may involve international transfers of data from you to Dell and/or to Dell's affiliates, subcontractors or business partners. When making such transfers, Dell shall ensure appropriate protection is in place to safeguard the Collected Data being transferred in connection with SupportAssist. If you are downloading SupportAssist on behalf of a company or other legal entity, you are further certifying to Dell that you have appropriate authority to provide this consent on behalf of that entity. If you do not consent to the collection, transmission and/or use of the Collected Data, you may not download, install or otherwise use SupportAssist.

_____AeroHive HiveManager NG EULA_____

This switch includes a feature that enables it to work with HiveManager (an optional management suite), by sending the switch's service tag number and IP Address to HiveManager to authenticate your entitlement to use HiveManager. If you wish to disable this feature, you should run command 'eula-consent hiveagent reject' immediately upon powering up the switch for the first time, or at any time thereafter.

Applying Global configuration, please wait...

Welcome to Dell Easy Setup Wizard

The setup wizard guides you through the initial switch configuration, and gets you up and running as quickly as possible. You can skip the setup wizard, and enter CLI mode to manually configure the switch. You must respond to the next question to run the setup wizard within 60 seconds, otherwise the system will continue

with normal operation using the default system configuration. Note: You can exit the setup wizard at any point by entering [ctrl+z].

Would you like to run the setup wizard (you must answer this question within 60 seconds)? [Y/N] **y**

Step 1:

The system is not set up for SNMP management by default. To manage the switch using SNMP (required for Dell Network Manager) you can

- . Set up the initial SNMP version 2 account now.
- . Return later and set up other SNMP accounts. (For more information on setting up an SNMP version 1 or 3 account, see the user documentation).

Would you like to set up the SNMP management interface now? [Y/N] **y**

To set up the SNMP management account you must specify the management system IP address and the "community string" or password that the particular management system uses to access the switch. The wizard automatically assigns the highest access level [Privilege Level 15] to this account. You can use Dell Network Manager or other management interfaces to change this setting, and to add additional management system information later. For more information on adding management systems, see the user documentation.

To add a management station:

Please enter the SNMP community string to be used.

[public]: **public**



NOTA: Si está configurado, el nivel de acceso predeterminado se establece en el acceso más elevado disponible para la interfaz de administración SNMP. En un principio, solo se activa SNMPv2. SNMPv3 permanece deshabilitado hasta que vuelva a configurar el acceso de seguridad para SNMPv3 (p. ej., id. de motor, vista, etc.).

Please enter the IP address of the Management System (A.B.C.D) or wildcard (0.0.0.0) to manage from any Management Station. [0.0.0.0]: **10.1.2.100**

Step 2:

Now we need to set up your initial privilege (Level 15) user account. This account is used to login to the CLI and Web interface. You may set up other accounts and change privilege levels later. For more information on setting up user accounts and changing privilege levels, see the user documentation.

To set up a user account:

Please enter the user name. [root]:**admin**
Please enter the user password: *********
Please reenter the user password: *********

Step 3:

Next, an IP address is set up on the VLAN 1 routing interface.

You can use the IP address to access the CLI, Web interface, or SNMP interface of the switch.

To access the switch through any Management Interface you can

- . Set up the IP address for the Management Interface.
- . Set up the default gateway if IP address is manually configured on the routing interface.

Step 4:

Would you like to set up the VLAN1 routing interface now? [Y/N] **y**

Please enter the IP address of the device (A.B.C.D) or enter "DHCP" (without the quotes) to automatically request an IP address from the network DHCP server:
10.1.1.200

Please enter the IP subnet mask (A.B.C.D or /nn):
255.255.255.0

Step 5:

Finally, set up the default gateway. Please enter the IP address of the gateway from which this network is reachable. [0.0.0.0]: **10.1.1.1**

This is the configuration information that has been collected:

```
SNMP Interface = "public"@10.1.2.100
User Account setup = admin
Password = *****
VLAN1 Router Interface IP = 10.1.1.200 255.255.255.0
Default Gateway = 10.1.1.1
```

Step 6:

If the information is correct, please enter (Y) to save the configuration and copy the settings to the start-up configuration file. If the information is incorrect, enter (N) to discard the configuration and restart the wizard: [Y/N] **y**

Thank you for using the Dell Easy Setup Wizard. You will now enter CLI mode.

Applying Interface configuration, please wait...

Pasos siguientes

Una vez que haya completado la configuración inicial que se describe en esta sección, conecte cualquier puerto del panel frontal del conmutador a una red de producción para la administración remota en banda.

Si ha especificado DHCP para la dirección IP de la interfaz de administración VLAN 1, un servidor DHCP de la red asignará la dirección IP a la interfaz. Para descubrir la dirección IP asignada de forma dinámica, utilice la conexión del puerto de consola para emitir el siguiente comando:

- Para la interfaz de enrutamiento VLAN 1, introduzca **show ip interface (mostrar interfaz IP)**.

Para acceder a la interfaz de Dell OpenManage Switch Administrator, introduzca la dirección IP de la interfaz de administración VLAN 1 en la barra de direcciones de un explorador web. Para obtener acceso de administración remota a la CLI, introduzca la dirección IP de la interfaz de administración VLAN 1 en un cliente Telnet o SSH. De forma alternativa, siga utilizando el puerto de consola para obtener acceso al conmutador mediante la CLI local.

El conmutador N2128PX-ON es compatible con características de conmutación básicas como VLAN y protocolo de árbol de expansión. Utilice la interfaz de administración basada en la web o la CLI para configurar las características requeridas por la red. Para obtener información acerca de la configuración de las características del conmutador, consulte la *Guía de configuración del usuario* o la *Guía de referencia de la línea de comandos*, disponibles en la página web de soporte: dell.com/support.

Descripción general del hardware

N3132PX-ON

Esta sección contiene información acerca de las características del dispositivo y las configuraciones de hardware modular para el conmutador Dell Networking N3132PX-ON.

Consumo de energía de los conmutadores N3132PX-ON PoE

La Tabla 1-5 muestra la información de consumo de energía de los conmutadores N3132PX-ON. El consumo de energía del sistema es de 175 W. La asignación de energía PoE es de 500 W para una fuente de alimentación de 715 W.

Tabla 1-5. Consumo de energía de los conmutadores N3132PX-ON

Modelo	Tensión de entrada	Configuración de la fuente de alimentación	Consumo máximo de corriente constante (A)	Alimentación constante máxima (W)
N3132PX-ON	100 V/60 Hz	Una de 715 W	6,47 A	647,3 W
	110 V/60 Hz	Una de 715 W	5,79 A	636,1 W
	120 V/60 Hz	Una de 715 W	5,12 A	611,9 W
	220 V/50 Hz	Una de 715 W	2,85 A	621,7 W
	240 V/50 Hz	Una de 715 W	2,62 A	618,7 W

La Tabla 1-6 muestra la asignación de energía PoE, que es de 1200 W para dos fuentes de alimentación de 715 W.

Tabla 1-6. Asignación de energía PoE: 1200 W para dos fuentes de alimentación de 715 W

Modelo	Tensión de entrada	Configuración de la fuente de alimentación	Consumo máximo de corriente constante (A)	Alimentación constante máxima (W)
N3132PX-ON	100 V/60 Hz	Dos de 715 W	14,37 A	1429,8 W
	110 V/60 Hz	Dos de 715 W	12,95 A	1417,6 W
	120 V/60 Hz	Dos de 715 W	11,78 A	1409,1 W
	220 V/50 Hz	Dos de 715 W	6,35 A	1374,8 W
	240 V/50 Hz	Dos de 715 W	5,84 A	1372,5 W

La Tabla 1-7 muestra la asignación de energía PoE, que es de 750 W para una fuente de alimentación de 1100 W.

Tabla 1-7. Asignación de energía PoE: 750 W para una fuente de alimentación de 1100 W

Modelo	Tensión de entrada	Configuración de la fuente de alimentación	Consumo máximo de corriente constante (A)	Alimentación constante máxima (W)
N3132PX-ON	100 V/60 Hz	Una de 1100 W	9,41 A	937,1 W
	110 V/60 Hz	Una de 1100 W	8,48 A	929,7 W
	120 V/60 Hz	Una de 1100 W	7,69 A	918,3 W
	220 V/50 Hz	Una de 1100 W	4,16 A	904,3 W
	240 V/50 Hz	Una de 1100 W	3,81 A	902,3 W

La Tabla 1-8 muestra la asignación de energía PoE, que es de 1700 W para dos fuentes de alimentación de 1100 W.

Tabla 1-8. Asignación de energía PoE: 1700 W para dos fuentes de alimentación de 1100 W

Modelo	Tensión de entrada	Configuración de la fuente de alimentación	Consumo máximo de corriente constante (A)	Alimentación constante máxima (W)
N3132PX-ON	100 V/60 Hz	Dos de 1100 W	19,16 A	1911,2 W
	110 V/60 Hz	Dos de 1100 W	17,24 A	1892 W
	120 V/60 Hz	Dos de 1100 W	15,68 A	1873 W
	220 V/50 Hz	Dos de 1100 W	8,37 A	1819 W
	240 V/50 Hz	Dos de 1100 W	7,7 A	1819,2 W

La Tabla 1-9 muestra la asignación de energía PoE, que es de 1440 W para una fuente de alimentación de 1100 W + una de 715 W.

Tabla 1-9. Asignación de energía PoE: 1440 W para una fuente de alimentación de 1100 W + una de 715 W

Modelo	Tensión de entrada	Configuración de la fuente de alimentación	Consumo máximo de corriente constante (A)	Alimentación constante máxima (W)
N3132PX-ON	100 V/60 Hz	1100 W + 715 W	17,51 A	1748 W
	110 V/60 Hz	1100 W + 715 W	15,7 A	1722,3 W
	120 V/60 Hz	1100 W + 715 W	14,36 A	1704,2 W
	220 V/50 Hz	1100 W + 715 W	7,63 A	1663,1 W
	240 V/50 Hz	1100 W + 715 W	6,99 A	1656,3 W

Sistema de ventilación

Dos ventiladores refrigeran los conmutadores N3132PX-ON en una única unidad reemplazable en la instalación (FRU). De forma adicional, los conmutadores N3132PX-ON cuentan con un ventilador en cada fuente de alimentación interna.

Resumen de modelos N3132PX-ON

Tabla 1-10. Números normativos de los conmutadores N3132PX-ON

Nombre de modelo de comercialización (MMN)	Descripción	Unidad de fuente de alimentación (PSU)	Número de modelo normativo (RMN)	Número de tipo normativo (RTN)
N3132PX-ON	24 x 1 G/8 x 5 G/4 x 10 G SFP+/1 compartimento modular/1+1 PSU redundante conectable/32 puertos PoE de 60 W/1 módulo de ventilador extraíble	1100 W/ 715 W	E06W	E06W003

Instalación de N3132PX-ON

Montaje del conmutador N3132PX-ON en bastidor

Coloque el conmutador en el estante del bastidor o monte el conmutador directamente en un bastidor de 19 pulg. de ancho, compatible con EIA-310-E (métodos de cuatro postes, dos postes o con rosca). El sistema Dell ReadyRail se proporciona para las instalaciones de dos postes y de bastidor frontal de 1 unidad. El sistema ReadyRail incluye dos ensamblajes de rieles empaquetados por separado.



AVISO: Este es un material de consulta condensado. Lea las instrucciones de seguridad en el folleto Información de seguridad, medioambiental y normativa antes de empezar.



NOTA: Las ilustraciones de este documento no pretenden representar un conmutador específico.

Consideraciones sobre la seguridad del montaje del bastidor

- Carga del bastidor: la sobrecarga o la carga que no sea uniforme de los bastidores puede dar lugar a un error del estante o del bastidor, provocando daños en el equipo y posibles lesiones personales. Establezca los bastidores en una ubicación permanente antes de que empiece la carga. Monte los componentes empezando por la parte inferior del bastidor y continúe hasta la parte superior. No supere la capacidad de carga del bastidor.
- Consideraciones sobre la alimentación: conecte solo a la fuente de alimentación especificada en la unidad. Cuando se instalen varios componentes eléctricos en el bastidor, asegúrese de que la capacidad total de la alimentación del componente no supere la capacidad del circuito. Las fuentes de alimentación sobrecargadas y los cables de extensión suponen un peligro de incendio y de descarga.
- Temperatura ambiente elevada: si se ha instalado en un ensamblaje de bastidor cerrado, la temperatura de funcionamiento del entorno del bastidor puede ser superior a la temperatura ambiente de la habitación. Procure no superar la temperatura ambiente máxima de 45 °C del conmutador.

- Flujo de aire reducido: instale el equipo en el bastidor para respetar la cantidad necesaria de flujo de aire para un funcionamiento seguro del equipo.
- Conexión a tierra fiable: mantenga una conexión a tierra fiable del equipo montado en el bastidor. Preste especial atención a las conexiones de suministro que no sean conexiones directas al circuito derivado (por ejemplo, el uso de regletas de enchufes).
- No monte el producto con el panel posterior orientado hacia abajo.

Instalación de Dell ReadyRail System

El sistema de montaje de bastidores ReadyRail se proporciona para configurar fácilmente su bastidor para la instalación de su conmutador.

El sistema ReadyRail se puede instalar utilizando el método sin herramientas de 1 unidad o uno de los tres métodos posibles con herramientas de 1 unidad (montaje al ras de dos postes, montaje central de dos postes o cuatro postes con rosca).

Configuración sin herramientas de 1 unidad (orificio cuadrado de cuatro postes u orificio redondo sin rosca)

- 1 Con las alas de la brida de ReadyRail hacia afuera, coloque un riel entre el poste vertical izquierdo y derecho. Alinee y coloque las clavijas del riel de la brida posterior en el poste vertical posterior. En la Ilustración 1-3, el elemento 1 y sus extracciones muestran cómo aparecen las clavijas en los orificios cuadrados y redondos sin rosca.

Ilustración 1-3. Configuración sin herramientas de 1 unidad

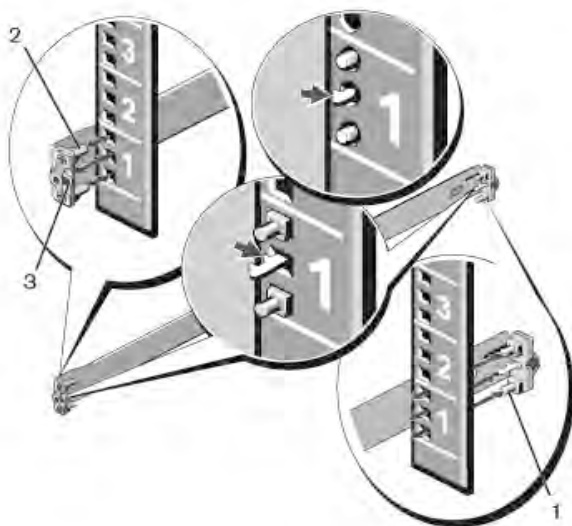

- 2 Alinee y coloque las clavijas de la brida frontal en los orificios del lado frontal del poste vertical. Consulte el elemento 2 de la Ilustración 1-3.
- 3 Repita este procedimiento con el segundo riel.
- 4 Para retirar los rieles, tire del botón del pasador de liberación de cada ala de la brida y retire los rieles. Consulte el elemento 3 de la Ilustración 1-3.

Configuración de montaje a ras de dos postes

- 1 Para esta configuración, debe extraer las piezas fundidas de la parte frontal de cada ensamblaje ReadyRail. Consulte el elemento 1 de la Ilustración 1-4 en la página 181. Utilice un destornillador Torx para retirar los dos tornillos de cada ala de la brida frontal (en el lado del conmutador del riel) y retire las piezas fundidas. Guarde las piezas fundidas por si son necesarias para el bastidor en el futuro. No es necesario retirar las piezas fundidas posteriores de la brida.

Ilustración 1-4. Configuración de montaje a ras de dos postes

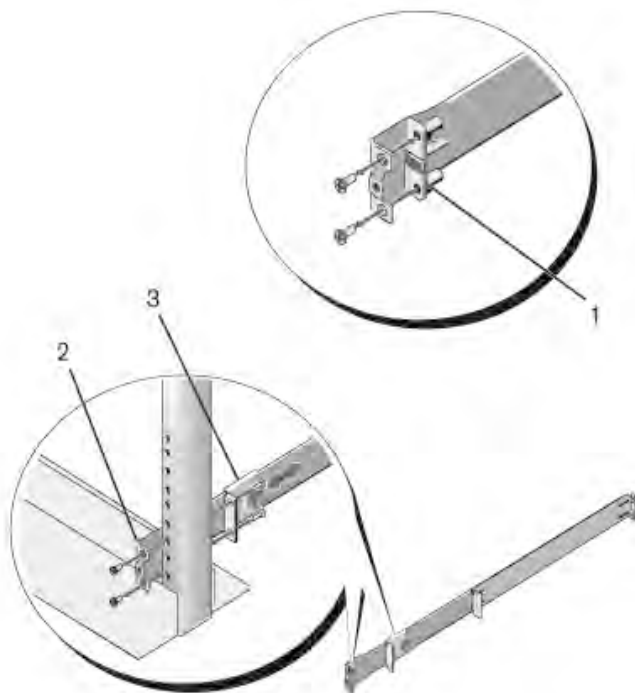

- 2** Fije un riel a la brida del poste frontal con dos tornillos del usuario. Consulte el elemento 2 de la Ilustración 1-4.
- 3** Deslice el soporte del pistón hacia el poste vertical y fije el soporte del pistón a la brida del poste con dos tornillos del usuario. Consulte el elemento 3 de la Ilustración 1-4.
- 4** Repita este procedimiento con el segundo riel.

Configuración de montaje central de dos postes

- 1** Deslice el soporte del pistón hacia atrás hasta que se oiga un clic y fije el soporte a la brida del poste frontal con dos tornillos del usuario. Consulte el elemento 1 de la Ilustración 1-5.

Ilustración 1-5. Configuración de montaje central de dos postes

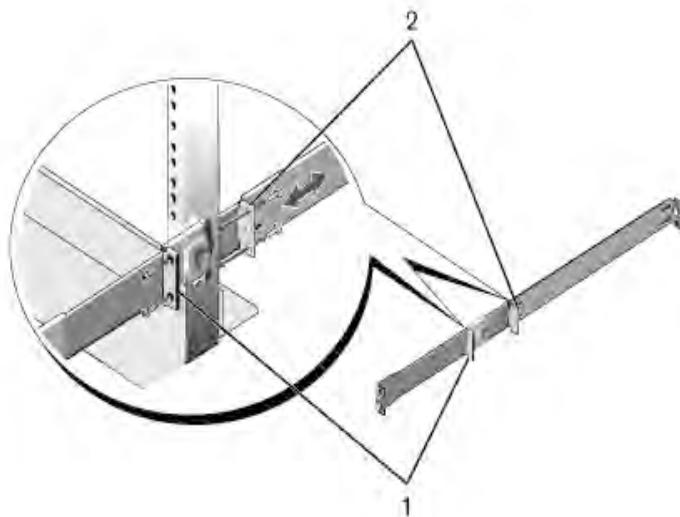

- 2 Deslice el soporte posterior hacia el poste y fíjelo en la brida del poste con dos tornillos del usuario. Consulte el elemento 2 de la Ilustración 1-5.
- 3 Repita este procedimiento con el segundo riel.

Configuración con rosca de cuatro postes:

- 1 Para esta configuración, debe extraer las piezas fundidas del ala de la brida de los extremos de los ensamblajes ReadyRail. Utilice un destornillador Torx para sacar los dos tornillos de las alas de la brida y retire las piezas fundidas. Consulte el elemento 1 de la Ilustración 1-6. Guarde las piezas fundidas por si son necesarias para el bastidor en el futuro.
- 2 En cada riel, fije las bridas frontal y posterior a las bridas del poste con dos tornillos del usuario en cada extremo. Consulte el elemento 2 de la Ilustración 1-6.

Ilustración 1-6. Configuración con rosca de cuatro postes:

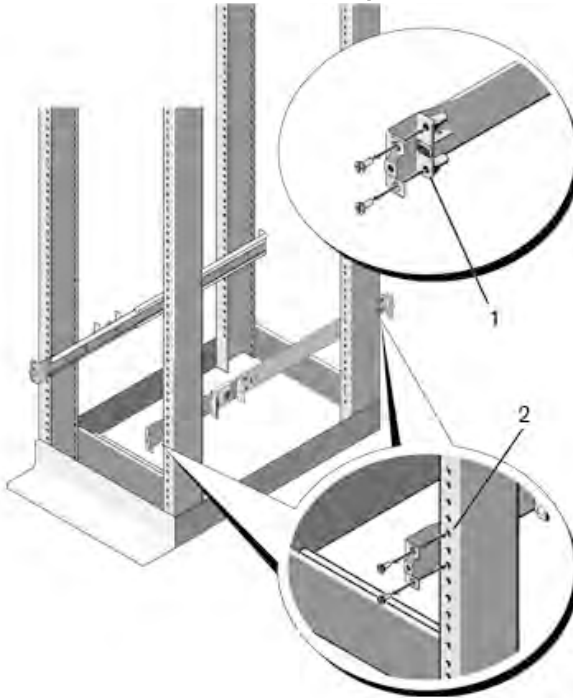

Instalación independiente del conmutador



NOTA: Dell recomienda encarecidamente montar el conmutador en un bastidor.

Si no es posible montar el conmutador en un bastidor, instálelo en una superficie plana. Dicha superficie debe ser capaz de sostener el peso del conmutador y de los cables del conmutador. El conmutador se envía con cuatro almohadillas de goma autoadhesivas.

- 1 Fije las almohadillas de goma autoadhesivas en las ubicaciones marcadas en la parte inferior del conmutador.
- 2 Coloque el conmutador en una superficie plana y asegúrese de que cuenta con una ventilación adecuada. Para ello, deje 5 cm (2 pulg.) de espacio libre a cada lado y 13 cm (5 pulg.) en la parte posterior.

Apilamiento de varios conmutadores N3132PX-ON

Es posible apilar varios conmutadores N3132PX-ON, hasta una altura de 12 conmutadores, mediante el uso de los puertos mini-SAS ubicados en el módulo de ampliación de apilamiento opcional que se puede introducir en la parte posterior del conmutador. Cuando se interconectan varios conmutadores a través de los puertos de pila, funcionan como una unidad única. Para obtener más información, consulte la *Guía de configuración del usuario* y la *Guía de referencia de la línea de comandos*.

Inicio y configuración del conmutador N3132PX-ON

El siguiente diagrama de flujo de la Ilustración 1-7 proporciona una descripción general de los pasos que debe seguir para realizar la configuración inicial del conmutador, una vez que este se ha desembalado y montado.

Ilustración 1-7. Diagrama de flujo de instalación y configuración

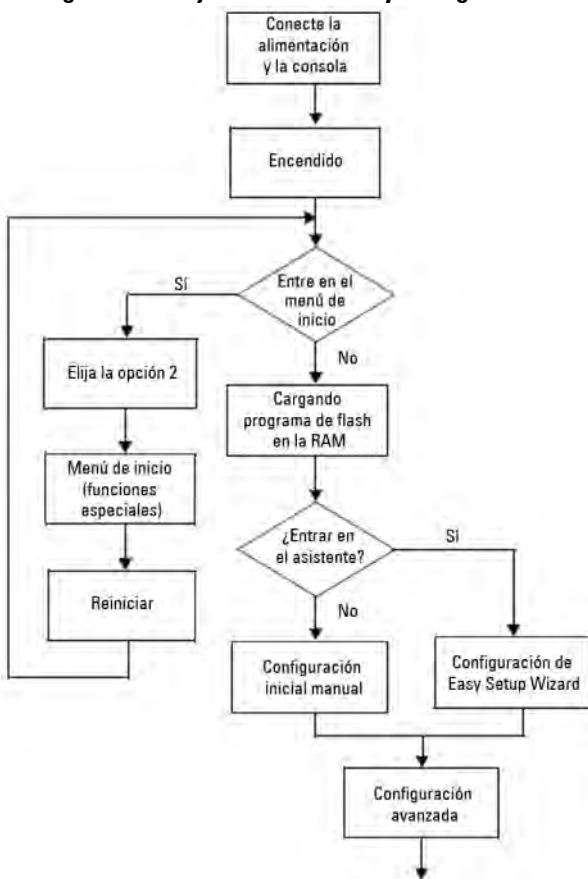

Conexión de un conmutador N3132PX-ON a un terminal

Tras realizar todas las conexiones externas, configure el conmutador. Para ello, conéctelo a un terminal.



NOTA: Lea las notas de la versión de este producto antes de continuar. Puede descargar las notas de la versión de la página web de soporte de Dell en dell.com/support.



NOTA: Dell recomienda obtener la versión más reciente de la documentación del usuario de la página web de soporte de Dell en dell.com/support.

Para supervisar y configurar el conmutador mediante la consola serie, utilice el puerto de consola del panel frontal del conmutador (consulte la Ilustración 1-8 en la página 187) para conectarlo a un terminal VT100 o a un equipo que ejecute el software de emulación de terminal VT100. El puerto de consola se implementa como un conector DTE (Data Terminal Equipment).

El siguiente equipo es necesario para utilizar el puerto de consola:

- Terminal compatible con VT100 o un equipo con un puerto serie que ejecute el software de emulación de terminal VT100, como por ejemplo Microsoft HyperTerminal.
- Un cable serie (proporcionado) con un conector RJ-45 para el puerto de consola y un conector DB-9 para el terminal.

Realice las siguientes tareas para conectar un terminal al puerto de consola del conmutador:

- 1 Conecte el conector DB-9 del cable serie al terminal o equipo que ejecute el software de emulación de terminal VT100.
- 2 Configure el software de emulación de terminal de la siguiente manera:
 - a Seleccione el puerto serie correspondiente (por ejemplo, COM 1) para conectar a la consola.
 - b Establezca la velocidad de los datos a 115,200 baudios.
 - c Establezca el formato de los datos en 8 bits, 1 bit de detención y sin paridad.
 - d Establezca el control de flujo en ninguno.
 - e Establezca el modo de emulación de terminal en VT100.

- f Seleccione las Teclas de terminal para Función, Flecha y teclas Ctrl. Asegúrese de que el valor establecido es para las teclas del terminal (no para las teclas de Microsoft Windows).
- 3 Conecte el conector RJ-45 del cable directamente al puerto de consola del conmutador. El puerto de consola Dell Networking se encuentra en la parte derecha del panel frontal y está marcado con el símbolo |O|O|, como se muestra en la Ilustración 1-8.



NOTA: El acceso de la consola serie al administrador de pilas está disponible desde cualquier puerto serie mediante la CLI local. Solo se permite una sesión de consola serie a la vez.

Ilustración 1-8. Ubicación del puerto de consola en N3132PX-ON

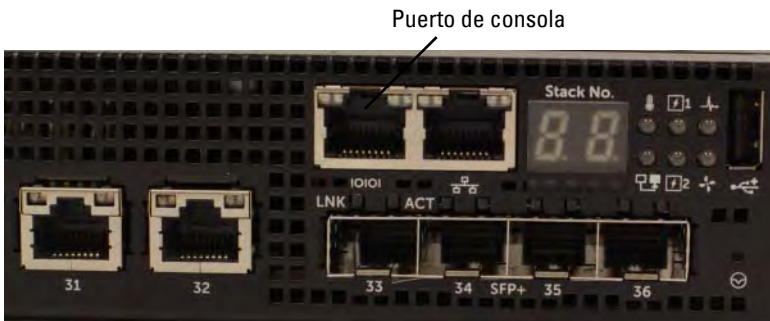

El puerto RJ-45 que se encuentra a la derecha del puerto de consola es para la administración Ethernet fuera de banda.

Conexión de un conmutador N3132PX-ON a una fuente de alimentación

PRECAUCIÓN: Lea la información de seguridad incluida en el manual de *Información de seguridad y normativa*, así como la información de seguridad de cualquier otro conmutador que se conecte al conmutador o sea compatible con el mismo.

Los conmutadores N3132PX-ON cuentan con dos fuentes de alimentación FRU para operaciones de carga compartida o redundante.

Ilustración 1-9. Dos fuentes de alimentación redundantes en N3132PX-ON



Dos fuentes de alimentación de CA

Conexiones de alimentación de CA y de CC

- 1 Asegúrese de que el puerto de consola del conmutador está conectado a un terminal VT100 o a un emulador de terminal VT100 a través del cable RJ-45 al cable DB-9 hembra.
- 2 Mediante el uso de un cable de alimentación estándar de 1,5 m (5 ft) con la toma a tierra de seguridad conectada, conecte el cable de alimentación al conector principal de CA, que se encuentra en el panel posterior.
- 3 Conecte el cable de alimentación a un enchufe de CA con toma a tierra.

Inicio del conmutador N3132PX-ON

Cuando la alimentación esté activada y el terminal local ya se haya conectado, el conmutador realizará una autopruueba de encendido (POST). La POST se ejecuta cada vez que se inicializa el conmutador y analiza los componentes de hardware para determinar si el conmutador está totalmente operativo antes de iniciarlo por completo. Si la POST detecta un problema crítico, el flujo de programa se detiene. Si la POST se ejecuta correctamente, el firmware válido se carga en la RAM. Los mensajes de la POST se muestran en el terminal e indican que la prueba se ha realizado correcta o incorrectamente. El proceso de inicio se ejecuta durante 60 segundos aproximadamente.

Una vez que se haya completado la primera parte de la POST, puede invocar el menú **Inicio**. Desde el menú **Inicio**, puede realizar tareas de configuración, como el restablecimiento del sistema a los valores predeterminados de fábrica, la activación de la imagen de copia de seguridad o la recuperación de una contraseña. Para obtener más información acerca de las funciones del menú **Inicio**, consulte la *Guía de referencia de línea de comandos*.

Cómo realizar la configuración inicial de N3132PX-ON

El procedimiento de configuración inicial toma por supuesto lo siguiente:

- El conmutador Dell Networking no se ha configurado anteriormente.
- El conmutador Dell Networking se ha iniciado correctamente.
- Se ha establecido conexión con la consola y la petición de **Dell Easy Setup Wizard** aparece en la pantalla de un terminal VT100 o de un terminal equivalente.

La configuración inicial del conmutador se realiza a través del puerto de consola. Tras la configuración inicial, puede administrar el conmutador desde el puerto de consola ya conectado o de forma remota a través de una interfaz definida durante la configuración inicial.



NOTA: El conmutador no se configura con un nombre de usuario predeterminado ni una contraseña. La dirección IP predeterminada se establece en DHCP para el puerto fuera de banda (OOB).

Antes de realizar la configuración inicial del conmutador, obtenga la siguiente información de su administrador de red:

- La dirección IP que se asignará a la interfaz de administración.
- La máscara de subred IP para la red.
- La dirección IP de la puerta de enlace predeterminada de la interfaz de administración.

Estos valores son necesarios para permitir la administración remota del conmutador a través de Telnet (cliente Telnet) o HTTP (explorador web).

Activación de la administración remota

El panel frontal del conmutador N3132PX-ON dispone de un puerto Gigabit Ethernet para la administración OOB. El puerto OOB se encuentra a la derecha del puerto de consola. Los conmutadores N3132PX-ON permiten el uso del puerto OOB o de cualquier puerto del panel frontal del conmutador para la administración en banda. De forma predeterminada, todos los puertos en banda son miembros de VLAN 1.

Dell Easy Setup Wizard incluye peticiones para configurar la información de red para la interfaz de administración OOB en el conmutador N3132PX-ON y para la interfaz VLAN 1 en los conmutadores N3132PX-ON. Para cualquiera de las interfaces de administración, puede asignar una dirección IP estática y una máscara de subred, o habilitar DHCP y permitir que un servidor DHCP de red asigne esta información.

Para obtener información acerca de los comandos para configurar la información de red, consulte la *Guía de referencia de la línea de comandos*.

Procedimiento para la configuración inicial

Lleve a cabo la configuración inicial mediante el uso de **Dell Easy Setup Wizard** o de la CLI. El asistente se inicia automáticamente cuando el archivo de configuración del conmutador está vacío. Puede abandonar el asistente en cualquier momento pulsando las teclas [Ctrl + z], pero esto hará que se descarten todos los valores de configuración especificados y que el conmutador utilice los ajustes predeterminados.



NOTA: Si no ejecuta **Dell Easy Setup Wizard** o no responde a la petición inicial de Easy Setup Wizard en 60 segundos, el conmutador entrará en el modo CLI. Para volver a ejecutar **Dell Easy Setup Wizard**, deberá restablecer el conmutador con una configuración de inicio vacía.

Para obtener más información acerca de la configuración inicial mediante el uso de la CLI, consulte la *Guía de referencia de la línea de comandos*. Esta *Guía de introducción* describe cómo utilizar **Dell Easy Setup Wizard** para la configuración inicial del conmutador. El asistente establece la siguiente configuración en el conmutador:

- Establece la cuenta de usuario privilegiada inicial con una contraseña válida. El asistente configura una cuenta de usuario privilegiada durante la configuración.
- Permite el inicio de sesión CLI y el acceso HTTP para utilizar únicamente el ajuste de autenticación local.
- Establece la dirección IP para la interfaz de administración OOB.
- Configura la dirección IP para la interfaz de enrutamiento VLAN 1, de la que todos los puertos en banda son miembros.

- Establece la cadena de comunidad SNMP que se va a utilizar por el administrador SNMP a una dirección IP determinada. Puede optar por omitir este paso si la administración SNMP no se utiliza para este conmutador.
- Permite especificar la dirección IP del sistema de administración de red o permite el acceso de administración desde todas las direcciones IP.
- Configura la dirección IP de la puerta de enlace predeterminada para la interfaz VLAN 1.

Sesión de ejemplo

Esta sección describe una sesión de **Dell Easy Setup Wizard**. Los siguientes valores se utilizan en la sesión de ejemplo:

- La cadena de comunidad SNMP que va a utilizar es **pública**.
- La dirección IP del sistema de administración de red (NMS) es **10.1.2.100**.
- El nombre de usuario es **admin** y la contraseña es **admin123**.
- La interfaz de administración OOB utiliza **DHCP** para la asignación de direcciones IP.
- La dirección IP para la interfaz de enrutamiento VLAN 1 es **10.1.1.200** y la máscara de subred es **255.255.255.0**.
- La puerta de enlace predeterminada es **10.1.1.1**.

El asistente para la instalación configura los valores iniciales como se indica anteriormente. Una vez que el asistente finalice, el conmutador estará configurado de la siguiente forma:

- SNMPv2 se habilita y la cadena de comunidad se configura como se indica anteriormente. SNMPv3 se deshabilita de forma predeterminada.
- La cuenta del usuario administrador se configura como se indica anteriormente.
- Se configura un sistema de administración de red. Puede acceder a las interfaces SNMP, HTTP y CLI desde la estación de administración.
- DHCP se habilita en la interfaz de administración OOB.
- Se configura una dirección IP para la interfaz de enrutamiento VLAN 1.
- Se configura una dirección de puerta de enlace predeterminada.



NOTA: En el siguiente ejemplo, las posibles opciones de usuario o los valores predeterminados se encuentran entre corchetes []. Si pulsa <Intro> sin haber definido una opción, se aplica el valor predeterminado. El texto de ayuda se encuentra entre paréntesis.

Ejemplo de la consola de Dell Easy Setup Wizard

El siguiente ejemplo contiene la secuencia de peticiones y respuestas asociadas a la ejecución de una sesión de ejemplo de **Dell Easy Setup Wizard** mediante el uso de los valores de entrada indicados anteriormente.

Una vez que el conmutador complete la POST y se inicie, aparecerá el siguiente diálogo:

```
Unit 1 - Waiting to select management unit)>
```

```
_____Dell SupportAssist EULA_____
```

```
I accept the terms of the license agreement. You can  
reject the license agreement by configuring this  
command 'eula-consent support-assist reject'.
```

```
By installing SupportAssist, you allow Dell to save  
your contact information (e.g. name, phone number  
and/or email address) which would be used to provide  
technical support for your Dell products and services  
Dell may use the information for providing  
recommendations to improve your IT infrastructure.  
Dell SupportAssist also collects and stores machine  
diagnostic information, which may include but is not  
limited to configuration information, user supplied  
contact information, names of data volumes, IP  
addresses, access control lists, diagnostics &  
performance information, network configuration  
information, host/server configuration & performance  
information and related data (Collected Data) and  
transmits this information to Dell. By downloading  
SupportAssist and agreeing to be bound by these terms  
and the Dell end user license agreement, available at:  
http://www.dell.com/aeula, you agree to allow Dell to  
provide remote monitoring services of your IT  
environment and you give Dell the right to collect the  
Collected Data in accordance with Dell's Privacy  
Policy, available at:  
http://www.dell.com/privacypolicycountryspecific, in  
order to enable the performance of all of the various  
functions of SupportAssist during your entitlement to
```

receive related repair services from Dell. You further agree to allow Dell to transmit and store the Collected Data from SupportAssist in accordance with these terms. You agree that the provision of SupportAssist may involve international transfers of data from you to Dell and/or to Dell's affiliates, subcontractors or business partners. When making such transfers, Dell shall ensure appropriate protection is in place to safeguard the Collected Data being transferred in connection with SupportAssist. If you are downloading SupportAssist on behalf of a company or other legal entity, you are further certifying to Dell that you have appropriate authority to provide this consent on behalf of that entity. If you do not consent to the collection, transmission and/or use of the Collected Data, you may not download, install or otherwise use SupportAssist.

_____AeroHive HiveManager NG EULA_____

This switch includes a feature that enables it to work with HiveManager (an optional management suite), by sending the switch's service tag number and IP Address to HiveManager to authenticate your entitlement to use HiveManager. If you wish to disable this feature, you should run command 'eula-consent hiveagent reject' immediately upon powering up the switch for the first time, or at any time thereafter.

Applying Global configuration, please wait...

Welcome to Dell Easy Setup Wizard

The setup wizard guides you through the initial switch configuration, and gets you up and running as quickly as possible. You can skip the setup wizard, and enter CLI mode to manually configure the switch. You must respond to the next question to run the setup wizard within 60 seconds, otherwise the system will continue

with normal operation using the default system configuration. Note: You can exit the setup wizard at any point by entering [ctrl+z].

Would you like to run the setup wizard (you must answer this question within 60 seconds)? [Y/N] **y**

Step 1:

The system is not set up for SNMP management by default. To manage the switch using SNMP (required for Dell Network Manager) you can

- . Set up the initial SNMP version 2 account now.
- . Return later and set up other SNMP accounts. (For more information on setting up an SNMP version 1 or 3 account, see the user documentation).

Would you like to set up the SNMP management interface now? [Y/N] **y**

To set up the SNMP management account you must specify the management system IP address and the "community string" or password that the particular management system uses to access the switch. The wizard automatically assigns the highest access level [Privilege Level 15] to this account. You can use Dell Network Manager or other management interfaces to change this setting, and to add additional management system information later. For more information on adding management systems, see the user documentation.

To add a management station:

Please enter the SNMP community string to be used.
[public]: **public**



NOTA: Si está configurado, el nivel de acceso predeterminado se establece en el acceso más elevado disponible para la interfaz de administración SNMP. En un principio, solo se activa SNMPv2. SNMPv3 permanece deshabilitado hasta que vuelva a configurar el acceso de seguridad para SNMPv3 (p. ej., id. de motor, vista, etc.).

Please enter the IP address of the Management System (A.B.C.D) or wildcard (0.0.0.0) to manage from any Management Station. [0.0.0.0]: **10.1.2.100**

Step 2:

Now we need to set up your initial privilege (Level 15) user account. This account is used to login to the CLI and Web interface. You may set up other accounts and change privilege levels later. For more information on setting up user accounts and changing privilege levels, see the user documentation.

To set up a user account:

Please enter the user name. [root]:**admin**

Please enter the user password: *********

Please reenter the user password: *********

Step 3:

Next, IP addresses are set up on the OOB (Out-Of-Band) Interface and/or the VLAN 1 routing interface.

You can use these IP addresses to access the CLI, Web interface, or SNMP interface of the switch.

To access the switch through any Management Interface you can

- . Set up the IP address for the Management Interface.
- . Set up the default gateway if IP address is manually configured on both routing and OOB interface.

Would you like to set up the Out-Of-Band interface now? [Y/N] **y**

Please enter the IP address of the device (A.B.C.D) or enter "DHCP" (without the quotes) to automatically request an IP address from the network DHCP server.

[DHCP]: **dhcp**

Step 4:

Would you like to set up the VLAN1 routing interface now? [Y/N] **y**

Please enter the IP address of the device (A.B.C.D) or enter "DHCP" (without the quotes) to automatically request an IP address from the network DHCP server:
10.1.1.200

Please enter the IP subnet mask (A.B.C.D or /nn):
255.255.255.0

Step 5:

Finally, set up the default gateway. Please enter the IP address of the gateway from which this network is reachable. [0.0.0.0]: **10.1.1.1**

This is the configuration information that has been collected:

```
SNMP Interface = "public"@10.1.2.100
User Account setup = admin
Password = *****
Out-of-band IP address = DHCP
VLAN1 Router Interface IP = 10.1.1.200 255.255.255.0
Default Gateway = 10.1.1.1
```

Step 6:

If the information is correct, please enter (Y) to save the configuration and copy the settings to the start-up configuration file. If the information is incorrect, enter (N) to discard the configuration and restart the wizard: [Y/N] **y**

Thank you for using the Dell Easy Setup Wizard. You will now enter CLI mode.

Applying Interface configuration, please wait...

Pasos siguientes

Una vez que haya completado la configuración inicial que se describe en esta sección, conecte el puerto OOB a la red de administración para la administración remota fuera de banda, o conecte cualquier puerto del panel frontal del conmutador a una red de producción para la administración remota en banda.

Si ha especificado DHCP para la dirección IP de la interfaz de administración VLAN 1 u OOB, un servidor DHCP de la red asignará la dirección IP a la interfaz. Para descubrir la dirección IP asignada de forma dinámica, utilice la conexión del puerto de consola para emitir los siguientes comandos:

- Para la interfaz OOB, introduzca **show ip interface out-of-band (mostrar interfaz IP fuera de banda)**.
- Para la interfaz de enrutamiento VLAN 1, introduzca **show ip interface vlan 1 (mostrar interfaz IP VLAN 1)**.

Para acceder a la interfaz de Dell OpenManage Switch Administrator, introduzca la dirección IP de la interfaz de administración OOB en la barra de direcciones de un explorador web. Para obtener acceso de administración remota a la CLI, introduzca la dirección IP de la interfaz de administración VLAN 1 en un cliente Telnet o SSH. De forma alternativa, siga utilizando el puerto de consola para obtener acceso al conmutador mediante la CLI local.

El conmutador N3132PX-ON es compatible con características de conmutación básicas como VLAN y protocolo de árbol de expansión. Los conmutadores N3132PX-ON también son compatibles con funciones avanzadas de Capa 3, como el enrutamiento dinámico y la multidifusión. Utilice la interfaz de administración basada en la web o la CLI para configurar las características requeridas por la red. Para obtener información acerca de la configuración de las características del conmutador, consulte la *Guía de configuración del usuario* o la *Guía de referencia de la línea de comandos*, disponibles en la página web de soporte: dell.com/support.

Información de la NOM (sólo para México)

La información que se proporciona a continuación aparece en el dispositivo descrito en este documento, de conformidad con los requisitos de la Norma Oficial Mexicana (NOM):

Exportador:	Dell Inc. One Dell Way Round Rock, TX 78682
Importador:	Dell Computer de México, S.A. de C.V. Paseo de la Reforma 2620 - 11º Piso Col. Lomas Altas 11950 México, D.F.
Enviar a:	Dell Computer de México, S.A. de C.V. al Cuidado de Kuehne & Nagel de México S. de R.L. Avenida Soles No. 55 Col. Peñon de los Baños 15520 México, D.F.
Tensión de suministro:	Dell Networking N2128PX-ON/N3132PX-ON : De 100 V a 240 V CA
Frecuencia:	Dell Networking N2128PX-ON/N3132PX-ON : 50/60 Hz
Consumo máximo de corriente en estado constante:	N2128PX-ON: <ul style="list-style-type: none">• Circuito de 110 V: ~0,80 A• Circuito de 220 V: ~0,43 A N3132PX-ON: <ul style="list-style-type: none">• Circuito de 110 V: 0,8 0A• Circuito de 220 V: 0,40A
NOTA: La corriente que se indica aquí es para el consumo de una única fuente de alimentación.	